

# Microeconomics of the materials and energents consumption in a simulated copper casting process

I. Najdenov , R. Radiša , K. T. Raić

*An analytical model for the optimization of the consumption of materials and energents in a typical copper casting process based on a standard simulation procedure is presented. The proposed microeconomic analysis in correlation with the virtual manufacture of castings enabled a shortening of the time required to develop a product, as well as the fabrication of high quality castings, which could be a crucial contribution to the achievement of increased engineering adequacy and economic competitiveness.*

*In this sense, the article demonstrates the beneficial employment of mathematical programming within a systematic economic analysis. The analyzed casting process is a part of the metallurgical manufacturing operations of the Copper Smelter and Refinery Bor, Serbia.*

## INTRODUCTION

Copper is one of the most used metals with a substantial market segment in the chemical, machine, electro and electronic industries. Business dynamics in copper metallurgical processes exhibit a clear move from conventional copper making towards a more flexible process. It is evident that the market requires every new process design to be state of the art in order to render an acceptable return-on-investment. The market also forces existing plants to periodic upgrades in order to maintain competitiveness against newer production methods [1-3].

It is well known, that the concept of 'sustainable development' for energy use in industry mostly lies on the thermodynamic methods of (energy and exergy) analysis [4]. Similarly, classical metallurgical process design tends to emphasize the technical feasibility of operations with traditional design strategies relying on generalized metallurgical thermodynamic relations [5,6]. This approach offer little insight into the economics of a specific process. According to the paradigm developed in [7], process economics become the driving force for innovative technology development. Thus, the successful

integration of decision hierarchy with a thermodynamic and economic model leads to a systematic tool for the conceptual design of a metallurgical process.

Management of energent consumption of a process is extremely complex and compound, and requires the complete company management to be well familiar with the technological process, organization and its permanent innovation, the conditions of domestic and foreign markets and company competitiveness as well as to follow permanently costs according to production stages using an information system [8,9].

This "real life" situation was the reason to present this microeconomic analysis of a typical casting process in the Copper and Copper Alloy Casting Plant, which is a part of the great metallurgical system of the Copper Smelter and Refinery Bor, Serbia. Hence, the analysis was developed on the micro level and it includes technical indications, thermodynamically based simulation of the casting process as well as qualitative economic indicators (economical and profitable).

The aim of this work was to show the possibilities for reducing the reversal material (uncompleted production) to an optimal level in the technological production process of Tapping blocks, with the aim of saving energents and the overall costs.

A Tapping block is a permanent mould casting from  $\text{CuZn}_2$  alloy; a casting which the Copper and Copper Alloy Casting Plant Bor requires for the Melting Plant. It is used to close the opening of the reverberatory furnace after the copper matte has been cast into the pot. The annual requirement of the Melting Plant for this casting is 150 pieces with a total weight of 33 t (150 pcs · 0.220 t).

The first way presents the production of the mould casting according to the existing projected model used for many years (20 years), while the second way is the result of the application of innovation in the technological process, i.e., the application of simulation of the casting process [10, 11]. Mould casting production in the second way was preceded by a detailed analysis consisting of feeder head and pouring system into the system construction and calculation, as well as a three-dimensional layout in an appropriate mechanical program (SolidWorks), including the software packet Magmasoft [12] for simulation of the casting process. This operation resulted in a reduction of physical energent consumption (fuel oil D2, electrical energy), supplies of reversal material used in the production technological process, labor and equipment maintenance. Considering the participation of energents to the total cost for most mould casting is 30% to 35%, and the tendency in Serbia to correct the prices of energents according to world prices, energetics has become a key factor in every casting plant production from the aspect of improving the labor economy [13]. This means that competitiveness of a casting product on the domestic and world market mostly depends on the possibilities of savings in the consumption of energent, i.e., more rational utilization.

## ELEMENTS OF THE CASTING PROCESS

Copper scrap melting is performed in a fuel oil D2, tilting pot furnace of the Morgan BU type, with a capacity of 800 kg. The molten material,  $\text{CuZn}_2$  alloy, is cast from the furnace into a preheated pot, carried by crane to the casting location. Casting is performed in two sand moulds, from which the final products, Tapping

Ivan Najdenov  
Copper Smelter and Refinery Bor,  
19210 Bor, Đorda Vajferta 20-24, Serbia.

Radomir Radiša  
Lola Institute, Serbia, Belgrade,  
11030 Belgrade, Kneza Višeslava 70a,  
Serbia.

Karlo T. Raić  
Faculty of Technology and Metallurgy,  
University of Belgrade,  
11120 Belgrade, Karnegijeva 4, Serbia

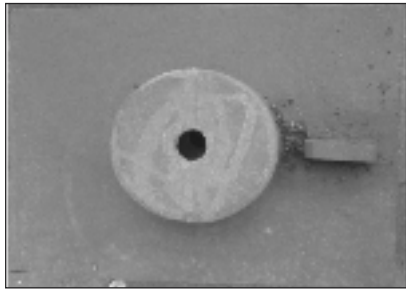

**Fig. 1. Tapping block.**

blocks, are obtained, after solidification and throwing off. Final product is shown in Figure 1.

It is worth noticing that copper scrap is a new material which is commonly formed into wire, pipes and sheets, while reversal material is generated in the technological process and consists of pouring system and feeder. A flowsheet of the production process, including a review of input and output, is given in Figure 2.

The casting procedure has become a highly developed technological process that has been improved in last decades [10]. Knowledge of the influence of significant parameters on the casting process and solidification enables the development of programs for simulation [11, 14–18]. Just to mention some commercial software: Magmasoft, Novacast, Flow3D, AnyCasting and many others.

The program packet Magmasoft [12] is a computer tool for simulating casting processes and casting solidification. It enables the testing of different technological casting procedures, without checking them in practice. To perform a simulation, a 3D geometric mould casting model and other components (pouring system, feeder

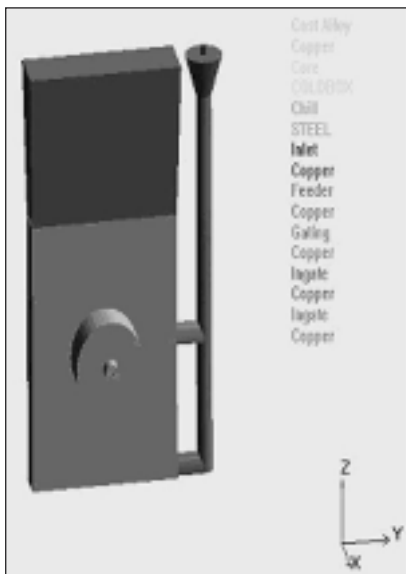

**Fig. 3. Tapping block layout with pouring system and feeder head.**

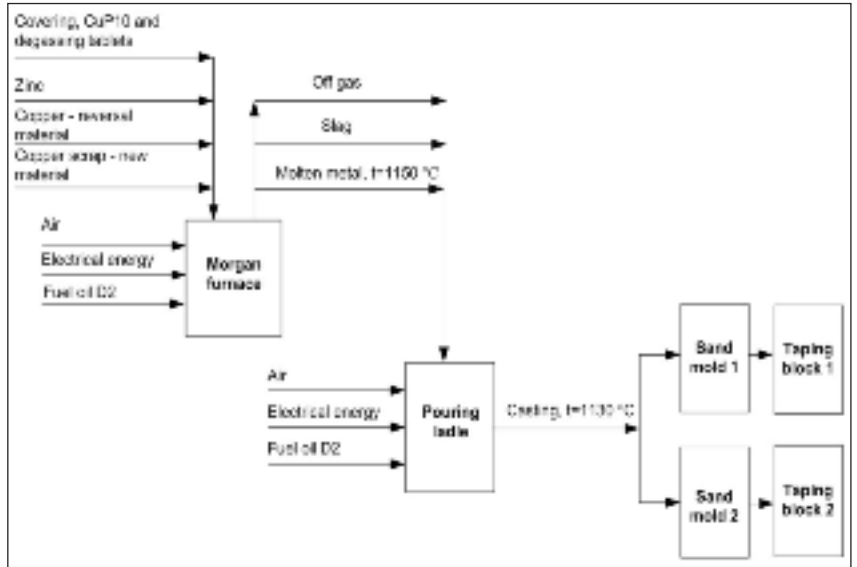

**Fig. 2. Flowsheet of Tapping blocks production process.**

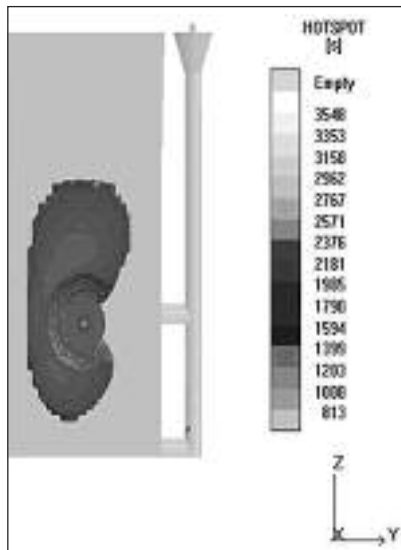

**Fig. 4. Process of mould cavity filling with hotspot review.**

head, filters, moulds, etc.), casting technology parameters (casting time and temperature, kinds of required materials), etc. must be provided. The module best accepted by MAGMA [12] is the input of the 3D geometric model record in STL format.

This work shows the application of the MAGMA [12] program packet to an actual mould casting sample casted in sand. The simulation and optimization of feeder is based on thermodynamic analyses of heat and mass transport in the mould cavity, with pre-determined parameters (type of alloy, system geometry, casting temperature = 1130 °C, temperature of cast solidification = 1083 °C, etc.). The layout of the Tapping block with pouring system and feeder head is shown in Figure 3. The process of mould cavity filling with a cop-

per cast with a review of the temperature differences at the hotspot is shown in Figure 4.

Construction data of the original and optimized feeder are given in the Table 1. As can be seen from Table 1, we were corrected the geometry parameters of the feeder. With the application of these dimensions and re-simulation in Magmasoft, healthy casting was obtained. In that way, the intersection (place where the casting and feeder are connected) had no casting defects. The left picture (Table 1) gives a cross section of the casting when used original feeder where can clearly be seen the casting defects due to poor feeding of the same (shrinkage porosity, porosity). The right picture (Table 1) gives a cross section of the casting when used optimized feeder. The advantage of optimized feeder is that, its weight reduced by 50 kg from the original feeder, so saving for a reversal material for annual production of 150 pieces of Taping blocks is 7.5 t. The production of 150 Tapping block pieces in a year means that the weight of the input charge can be reduced by reducing the weight of reversal material returning to technological process. In addition, it should be mentioned that two pieces of Tapping block could be cast from one charge.

## RESULTS

The flow dynamics of new and reversal material per charge for the production of two Tapping blocks is given by a linear equation:

$$b = c + a \quad (1)$$

where: a is the weight of reversal material, t; b is the weight of a charge and its

value can be from 0.68 to 0.78 t and  $c = 0.47$ , is a constant presenting the new material per charge, t.

The dynamics of reducing the quantity of reversal material per charge and reversal material required for the annual production of 150 pieces of Tapping block (33 t), is from 0.78 t to 0.68 t, i.e., from 23.25 t to 15.75 t.

The dependence between weight of reversal material per charge ( $a$ ) and the weight of reversal material for the annual production ( $k$ ) is given by equation 2:

$$a = 0.47 + 13.3 \cdot 10^{-3} \cdot k \quad (2)$$

By reducing charge weight from 0.78 t to the optimal weight of 0.68 t, reversal material is reduced by 0.1 t per charge or 7.5 t for the annual production. This difference in the quantity of reversal material increases the production costs related to supplies costs by an amount of 20.3 k€ for the annual production.

Equations 3, 4 and 5 present, respectively, the comparative physical consumption of D2 fuel oil, electrical energy and labor hours for the annual production taking into consideration the decrease in the amount of reversal material.

$$d = 8.59 \cdot 10^3 + 244 \cdot k \quad (3)$$

$$e = 1.62 \cdot 10^3 + 25 \cdot k \quad (4)$$

$$f = 18.7 \cdot 10^3 + 18.6 \cdot 10^2 \cdot k \quad (5)$$

where:  $d$  is consumption of D2 fuel oil, l;  $e$  is the consumption of electrical energy, kWh;  $f$  is the labor hours for the annual production, and  $k$  is the weight of reversal material for the annual production, t.

Figure 5 shows that a 7.5 t reduction of the amount of reversal material in the annual production results a saving of D2 fuel oil of 1827 l, of electrical energy of 188 kWh and of labor hours of 141 h.

### Dynamics of savings per piece of final product

Equations 6, 7 and 8 show the consumption of D2 fuel oil and electrical energy and the labor hours per piece on dependence on the dynamics of the reduction of reversal material for the annual production:

$$g = 56.8 + 1.65 \cdot k \quad (6)$$

$$h = 10.9 + 16.5 \cdot 10^{-2} \cdot k \quad (7)$$

$$i = 12.6 + 11.5 \cdot 10^{-2} \cdot k \quad (8)$$

where:  $g$  is the consumption of D2 fuel oil per piece of final product, l/pcs;  $h$  is the



Name	Original feeder	Optimized feeder
A, mm	462	462
B, mm	490	500
C, °	2.3	4.0
D, mm	80	80
E, mm	145	120
H, mm	350	270
F, °	5.3	4.2
Weight, t	0.155	0.105
Geometry		
Cross section		

Table 1. Construction data of the original and optimized feeder.

Fig. 5. Graphical presentation of the consumption for D2 fuel oil ( $d$ ) and electrical energy ( $e$ ) and labor hours ( $f$ ) in dependence of the dynamics of the reduction of the reversal material for the annual production.

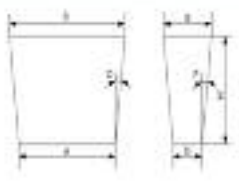
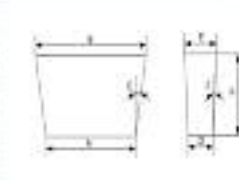
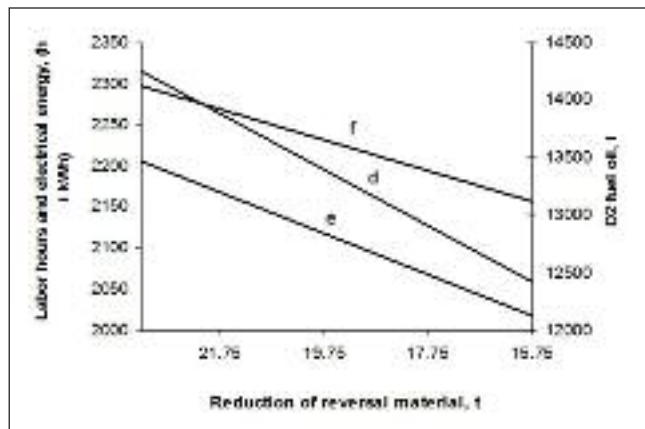
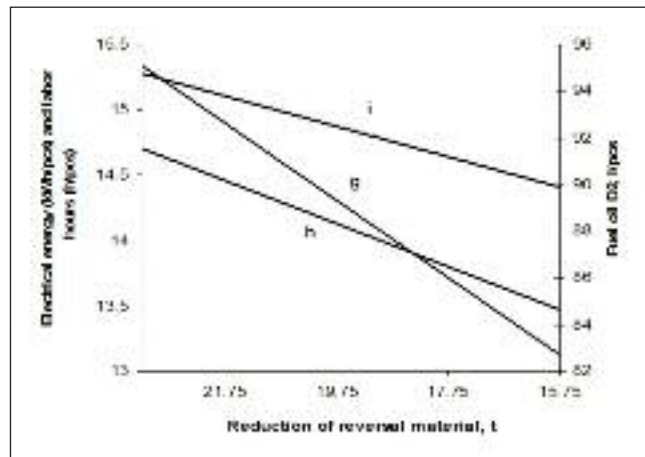

Fig. 6. Graphical presentation of the consumption for D2 fuel oil ( $g$ ) and electrical energy ( $h$ ), and the labor hours ( $i$ ) per piece of final product in dependence on the dynamics of the reduction of the amount of reversal material for the annual production.



**Table 2. Prices for a piece depending on the dynamics of the reduction of the reversal material at the annual level.**

Name	Price for annual production with charge of 0.78 t Euro/pcs	Price for annual production with charge of 0.68 t Euro/pcs
Normative production material	682	671
- raw material	591	590
- D2 fuel oil	76	67
- electrical energy	0.4	0.4
- other normatives	15	14
Depreciation	2	1
Maintenance	20	13
Earnings	16	15
Loss-earning financing	135	0
<b>TOTAL</b>	<b>855</b>	<b>700</b>

consumption of electrical energy per piece of final product, kWh/pcs;  $i$  is the labor hours per piece of final product, h/pcs, and  $k$  is the weight of reversal material for the annual production, t. Figure 6 shows the dynamics of the energents (D2 fuel oil, electrical energy) and labor hours in dependence on the reduction of reversal material for the annual production.

Table 2 gives the prices of Tapping block production using a charge of 0.78 t and the optimal charge of 0.68 t in the calculations and costs of supplies.

For example, for a reversal material reduction of 7.5 t, normatively the D2 fuel oil is reduced from 95 l/pcs to 83 l/pcs, the electrical energy from 15 kWh/pcs to 14 kWh/pcs, and labor hours from 15 h/pcs to 14 h/pcs.

The dynamics of the price, savings at the annual level as well as savings reduced to a piece of the final product are given by the linear equations 9, 10 and 11, respectively.

$$j = 394 + 19.2 \cdot k \quad (9)$$

$$l = 63 \cdot 10^3 - 2.71 \cdot 10^3 \cdot k \quad (10)$$

$$m = 419 - 18 \cdot k \quad (11)$$

where:  $j$  is the price per piece of final product, Euro/pcs;  $l$  is the savings for the annual production, Euro;  $m$  is the saving for the annual production reduced to piece of final product, Euro, and  $k$  is the weight of reversal material for the annual production, t.

Figure 7 shows that savings resulting from a reduction of the reversal material of 7.5 t is 20.3 k€, that certainly reduces the original price per piece of final product of 855 Euro/pcs to 700 Euro/pcs, i.e., a price reduction of 22 %.

## ECONOMY AND PROFITABILITY

The qualitative business indicators, economy (E) and profitability (R) were calculated based on the following formula [9]:

**Fig. 7. Graphical presentation of the price per piece of final product ( $j$ ), the savings for the annual production ( $l$ ) and the savings for the annual production reduced to a piece of the final product ( $m$ ) in dependence on the reduction of the reversal material for the annual production.**

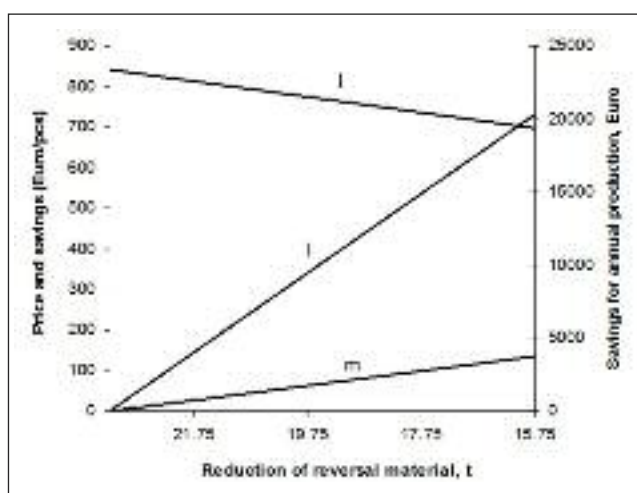

**Fig. 8. Graphical presentation of the dynamics of the economy ( $n$ ) and profitability ( $o$ ) in dependence on the reduction of the reversal material for the total production.**

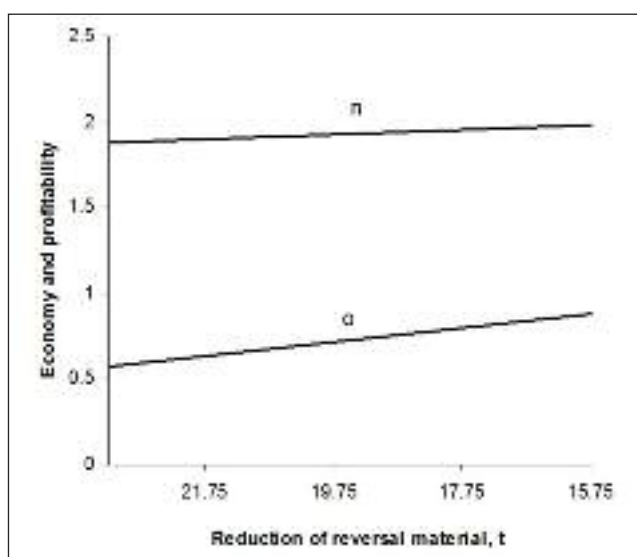

$$E = UP / TP \quad (12)$$

where: UP is the total income and TP is the business costs, including: M - normative material, raw material and semi manufactures and maintenance material, I - capital depreciation, L - costs of labor directly participating in the cast production and

$$R = P / S \quad (13)$$

where: P is the profit and S is the assets

engaged in the production.

The dynamics of the economy and profitability in dependence on the reduction of the reversal material are given by equations 14 and 15, respectively:

$$n = 2.19 - 13.3 \cdot 10^{-3} \cdot k \quad (14)$$

$$o = 1.52 - 40.8 \cdot 10^{-3} \cdot k \quad (15)$$

where:  $n$  is the economy;  $o$  is the profitability, and  $k$  is the weight of reversal ma-

material for the annual production, t.

Figure 8 shows the tendency of the economy to rise from 1.88 to 1.98 or 5.3 % and the profitability from 0.58 to 0.89, i.e., 53.4 % for a reduction in the reversal material of one tone, at the annual level.

Finally, the Figure 9 shows the elements of the suggested optimization with derived economy and profitability results, based on the typical variables i.e. geometric changes for feeder.

## DISCUSSION

The given analyses led to a charge fulfilling the technical conditions at minimal costs per unit of production. Savings from 20.3 k€ at the annual level can be presented by the following equivalents: supplying of 25062 liters of D2 fuel oil, i.e., purchasing of 8.1 t of raw material for the production of the CuZn2 alloy.

Significant savings by reducing the amount of reversal material can be achieved using this or a similar simulation program for the optimization of a casting process. For example, in a "Heidelberg" company, with an annual production of 1200 mould castings (weight of a casting is 0.20 t), the quantity of reversal material was reduced by 82.8 t, whereby a savings of 37.6 k€ was achieved [12]. The casting of grey iron (gear wheel) from the Heidelberg firm was used for comparison with the casting of Tapping blocks because of the following similarities: approximately same weight of castings, they are cast in sand moulds and the optimization of the feeders was realized for both. Considering the results obtained in the case of the production of 150 pieces of Tapping blocks (weight per piece is 0.22 t) at the annual level, when the quantity of reversal material was reduced by 7.5 tones which led to a saving of 20.3 k€, it can be confirmed that this is the same in world conditions.

Reversal material treated as scrap has a great influence on its price on the markets. Due to the complexity of the flow of copper material [19], this fact must be taken into account and incorporated in the economy and profitability calculations.

On the other hand, the sensitivity analysis of the electricity prices in a Swedish medium-sized iron foundry, SME, similar to the Serbia one, indicates that higher daily electricity prices resulted in higher system costs [20]. Hence, additional corrections of the presented results must also be developed.

## CONCLUSIONS

A casting process simulation was developed using the Magmasoft [12] program.

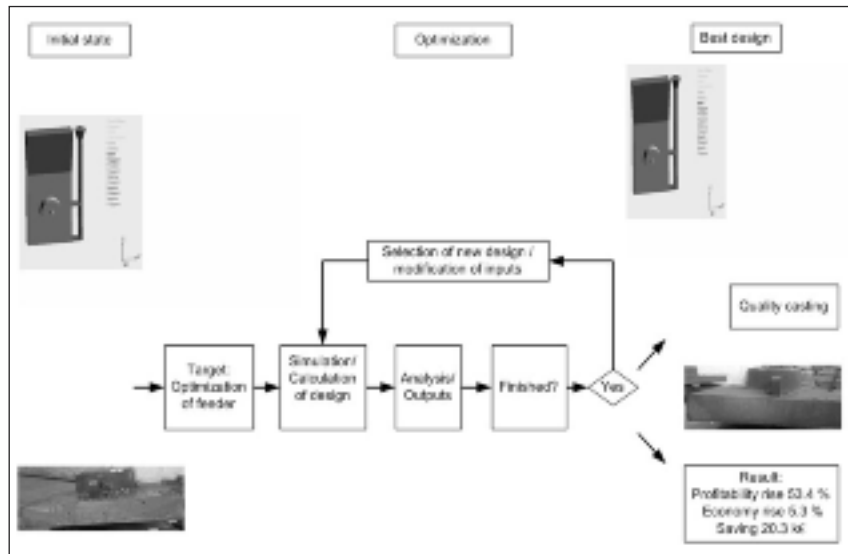

**Fig. 9. The elements of the suggested optimization with derived economy and profitability results.**

It showed that a regular design of the feeder head could reduce the quantity of reversal material by 7.5 t at the annual level and achieve significant saving in energetic consumption, leading to a reduction of total casting costs. In addition, the simulation results lead to conclusion that the quantity of input material could be reduced by 14.7 %, which means tendency of an economy rise of 5.3 % and profitability rise of 53.4 % at the annual level.

The presented analysis gave realistic possibilities for developing the optimization of the consumption of energents and labor hours and their better control for each mould cast from production program of the Copper and Copper Alloys Casting Plant, with the aim of realizing greater profits.

As the Copper and Copper Alloys Casting Plant produces a wide spectrum of products, from non-ferrous metals, the savings per one product at the annual level under condition of a lack of operating capital, could be of great significance for the continuation of production and even its expansion, as well as for the possibility of increasing earnings and new investments.

This works enables an analytical model to be obtained for other products within Copper and Copper Alloys Casting Plant, thereby creating possibilities for the rationalization of energent and material consumption, cost reduction and improved operation of the plant as a whole.

## Acknowledgements

This work has been supported by the Ministry of Science and Technological Development of the Republic of Serbia.

## FIGURE SOURCES

- /1/ with friendly permission of Copper and Copper Alloys Casting Plant Bor, Serbia.
- /3/ with friendly permission of Mr. Radomir Radiša (Lola Institute, Serbia, Belgrade), representative of Magma for Serbia.
- /4/ with friendly permission of Mr. Radomir Radiša (Lola Institute, Serbia, Belgrade), representative of Magma for Serbia.

## REFERENCES

- [1] Moreno A. (editor). World copper databook. Metal Bulletin Books. UK: Survey; 1999.
- [2] The homepage of Metal bulletin: 2009. <http://www.metalbulletin.com>
- [3] Alvarado S, Maldonado P, Barrios A, Jaques I. Long term energy-related environmental issues of copper production. Energy 2002;vol. 27, p. 83-96.
- [4] Hammond GP. Industrial energy analysis, thermodynamics and sustainability, Applied Energy 2007; vol. 84, p. 675-700.
- [5] Chakraborty A, Purkarthofer KA, Linninger AA. Conceptual design of metallurgical processes based on thermodynamic and economic insights. Chemical Engineering and Processing 2004; vol. 43, p. 625-640.
- [6] Linninger AA. Metallurgical process design-a tribute to douglas's conceptual design approach. Ind. Eng. Chem. Res. 2002; vol. 41, p. 3797-3805.
- [7] Douglas JM. A hierarchical decision procedure for process synthesis. AIChE J. 1985; vol. 31, p. 353-362.

- [8] Robbins S, Coulter M. Management. Pearson Education. New Jersey: 2005.
- [9] Charles M, Thomas R. Managerial Economics. New York. Mc Graw-Hill: 2002.
- [10] Robert D. Pehlke. Computer Simulation of Solidification Processes - The Evolution of a Technology. Metallurgical And Materials Transactions B. August 2002; vol. 33B, p. 519.
- [11] The homepage of Magma. <http://www.magma-soft.de>
- [12] E. Flender and J. Sturm. Thirty years of casting process simulation. International Journal of Metalcasting: Spring 2010.
- [13] Najdenov I, Rai K and Kokeza G. Economic insight into energents consumption in copper melting and refining plants of Serbia using the method of reduction to conditional fuel (coal equivalent). Metalurgia International 2011; 16, No. 10.
- [14] Pustal B, Ludwig A, Sahn P.R., Bührig-Polaczek A, Böttger B. Simulation of macroscopic solidification with an incorporated one dimensional microsegregation model coupled to thermodynamic software. Met. Mat. Trans. 2003; vol. 34B, p. 411-419.
- [15] Midea AC, Burns M, Schneider M, Wagner I. Advanced thermo-physical data for casting process simulation-the importance of accurate sleeve properties. Foundry Research/Giesereiforschung. 2007; vol. 59, p. 34-43.
- [16] Hartmann G, Egner-Walter A. Optimized development of castings and casting processes. In: International Congress on FEM Technology, Berlin, Germany: 2001.
- [17] Hansen PN, Hartmann G, Sturm JC. Optimised development for castings and casting processes-Increase in value by applying an integrated CAE Chain for the Development of Automotive Castings. In: 65th World Foundry Congress, Kyongju, Korea: 2002.
- [18] Kokot V, Bernbeck P. Integration and application of optimization algorithms with casting process simulation. In: Modelling of Casting, Welding and Advanced Solidification Processes X, Destin: 2003.
- [19] Kuckshinrichs W, Zapp P, Poganietz W-R. CO2 emissions of global metal-industries. The case of copper, Applied Energy 2009; vol. 84, p. 842-852.
- [20] Thollander P, Mardan N, Karlsson M. Optimization as investment decision support in a Swedish medium-sized iron foundry - A move beyond traditional energy auditing, Applied Energy 2009; vol. 86, p. 433-440.

## La Metallurgia Italiana

*“La Metallurgia Italiana” pubblica - in lingua italiana o inglese - memorie originali ed inedite che si riferiscano a lavori a carattere sperimentale o teorico, concernenti metalli ferrosi e non ferrosi ed altri materiali di interesse per applicazioni strutturali e funzionali, rivolti a varie aree metallurgiche: fisica, chimica e meccanica. Rassegne critiche pertinenti ad argomenti specifici sono pure di interesse per la rivista. Gli autori sono invitati a presentare i loro lavori in una forma concisa e comprensibile agli specialisti dei materiali e non solo agli addetti ai lavori chiamati in causa nei singoli testi. Le memorie inviate vengono sottoposte in forma anonima al giudizio di tre referee, competenti per il tema trattato.*

### Norme per gli Autori

Il testo deve essere inviato alla Segreteria di redazione o ad uno dei membri del Comitato Scientifico della rivista e deve essere redatto in modo da non superare 12 pagine. Nel testo si dovranno evitare tassativamente riferimenti a scopo commerciale (sigle, ragioni sociali, nomi di fabbrica).

Ogni manoscritto dovrà essere corredato da:

- Titolo - in edizione bilingue (italiano e inglese)
- Autori - nome degli autori, dell'ente di appartenenza e recapito.
- Riassunto - breve (di circa 300 battute), che illustri gli scopi del lavoro e ne riassume le conclusioni
- Sintesi estesa - in inglese (o in italiano, se la memoria viene presentata in inglese) di circa 1 o 2 pagine con eventuale citazione delle figure e delle tabelle più significative.
- Tabelle e figure - in numero non superiore a 12, ordinate secondo la numerazione araba. Per le micrografie, le indicazioni degli ingrandimenti vanno inserite all'interno delle figure stesse.
- Didascalie di tutte le figure e tabelle
- in edizione bilingue (italiano e inglese).
- Bibliografia - riportata nello stesso ordine di citazione dei riferimenti nel testo.

Per tutte le unità di misura, gli Autori devono attenersi all'International Unit System SI.

La corrispondenza deve essere inviata a:

**La Metallurgia Italiana,**  
c/o AIM - P.le R. Morandi 2  
20121 Milano,  
tel. 0276021132, fax 0276020551,  
oppure a: [met.aim@aimnet.it](mailto:met.aim@aimnet.it).