

# Laser Repairing Techniques for Superalloy Components

M. BALBI - Politecnico of Milan - ITALY, M. BRACCHETTI - Politecnico of Milan - ITALY, D. D. ANGELO ENEL/CRTN Milan - ITALY, C. GALLO - Politecnico of Milan - ITALY, G. P. MOR - CISE S.p.A. Segrate (MI) - ITALY

## Abstract

*It has been found that ordinary means of repair, applied to turbine blades and vanes, can adversely affect material properties and behaviour. High heat input generates important internal stresses and metallurgical phase transformations. Distortion effects and in a relatively wide heat affected zone (HAZ) are caused. The laser features, such as the high energy concentration and the power transfer rate from source to workpiece, allow to achieve a low heat input welding with reduced HAZ and distortion. The present paper is aimed to assess the cladding and welding characteristics in terms of heat input, morphological and microstructural properties. In particular, Co-base (X40) and Ni-base (IN738) superalloys have been considered.*

## Riassunto

Si è riscontrato che i metodi di riparazione tradizionale, se applicati alle pale ed al distributore di una turbina, possono avere un effetto negativo sulle proprietà e sui comportamenti dei materiali. Un input termico eccessivamente elevato comporta notevoli sollecitazioni interne e trasformazioni delle fasi metallurgiche. Si causano effetti di distorsione in una zona di riscaldamento (HAZ) relativamente ampia. Le caratteristiche del laser, quali l'alta concentrazione di energia e l'elevato tasso di trasferimento di energia dalla fonte al pezzo in lavorazione, consentono di ottenere una saldatura con un input termico relativamente modesto e con HAZ e distorsione ridotte. Questo articolo si propone di valutare le caratteristiche dei rivestimenti e delle saldature in termini di input termico e delle proprietà morfologiche e microstrutturali. In particolare, sono state prese in esame le superleghe Co-base (X40) e Ni-base (IN738).

## Introduction

Gas turbine components exposed to high temperature gases are liable to damage by a variety of causes. Some of the common damage forms are localized erosion/corrosion cracking, due to thermal fatigue, foreign-body impact, creep etc. and missing portions of the component. Very high costs of new components and very long time for their delivery have provided the impetus for a worldwide interest in refurbishment of damaged components. Replacements of damaged gas turbine parts can be very expensive and substantial cost saving can be made [1].

It is estimated that, for life limiting components, e.g. cast turbine rotor blades, 20% have been repaired and a further 20% scrapped before service.

An estimated 50% of these scrapped components are below drawing tolerance which could be recovered if a suitable repair procedure existed.

To-date such repairs have been carried out primarily on stationary components, and even on these only in regions which are operating at relatively low stresses, because existing repair techniques result in weak repair zones.

For example, a precipitation hardened stationary blade with cracks or missing portions, can be repaired by brazing or GTAW welding but the properties of the repaired blades are significantly poorer than those of the parent material, partly because low strength fillers are used for brazing and welding and partly because complex microstructures develop after the brazing/welding cycle [2][3].

European industries do not appear to repair turbine blades, even stationary ones, by welding new inserts although such repairs are carried out in the United States.

Laser welding and cladding processes are characterized by some typical features, such as high energy concentration, that allow a low heat input with limited heat affected zone (HAZ) and distortions.

Thus laser processes are expected to exhibit high dimensional control of the welded seam allowing little post-process machining and they are convenient for the process of crack sensitive alloys.

Moreover the high flexibility of the laser power supply drivers and of the beam delivery systems make the integration of laser in automated welding workstation appealing. Research efforts and investments in this field are justified by the large dimension of the market.

The current world market for industrial turbine rotor and stator blades is estimated to be 400 million USD for which an estimated 33% are manufactured in Europe i.e. 132 million USD, with the 20% of European share being sold outside the EEC.

By the year 2000 the world market is expected to be 1200 million USD with the European share falling to 30%, i.e. 380 million USD.

## **Features of laser welding and cladding**

Two different kinds of laser sources can be used for material processing applications, namely Nd:YAG and CO<sub>2</sub> lasers.

The active medium of Nd:YAG lasers is a crystal rod and the pumping is provided by discharge flash lamps. Nd:YAG laser can operate in continuous mode (c.w.) or, more frequently, in pulsed mode.

By modulating the current of the lamps, an accurate modulation of the pump energy can be done; this makes possible to define the shape of each single pulse at rates up to 10 kHz.

Typical output power of Nd:YAG laser is in the range of 100-1000 W; the wave length of the emitted radiation makes possible the transmission of the beam with optical fibers.

Nd:YAG lasers are widely used in the gas turbine industry for drilling (cooling holes and inserts) and for low thickness welding of cooling inserts; spot welding (e.g. honeycomb manufacturing) is also widespread. Structural welding of medium thickness (1-3 mm) sections is not yet of common practice.

CO<sub>2</sub> lasers use a mixture of gas (He, N<sub>2</sub>, CO<sub>2</sub>) as active medium. They can operate in pulsed or continuous wave (c.w.) mode but, in pulsed mode, it is not possible to get an effective pulse shaping. The typical output power is in the range of 1-10 kW.

CO<sub>2</sub> lasers are used in a number of applications for cutting, welding and cladding but their introduction in production and maintenance cycles is just at the beginning.

In particular cutting of damaged parts and welding of new inserts, labyrinth seals and blade tips build up and repairing of leading and trailing edges are performed. Some cladding of new parts is also executed.

The applications of laser processing that have been already developed and transferred in production are indicated in fig. 1.

## **Welding**

Laser welding is commonly classified as autogenous welding system, although filler metal (powder or wire) can be used. The heat input associated to CO<sub>2</sub> laser welding is given in fig. 2: the heat input vs. thickness curve is not linear, being not linear the dependence of the thickness from the welding speed.

For example, a 2 kW CO<sub>2</sub> laser beam is able to weld 4 mm of Ni alloy at approximately 1 m/min and 2 mm at 3 m/min. The comparison with other welding techniques commonly used in repairing, such as TIG or plasma (fig. 3), clearly demonstrates the advantages of laser techniques. It is worth to note that the low heat input makes it possible autogenous welding of highly gamma prime reinforced alloys, where usually weaker filler metal is required.

Up to now application fields of CO<sub>2</sub> and Nd:YAG laser haven't shown any overlap, being CO<sub>2</sub> used for continuous cutting and seam welding and Nd:YAG dedicated to drilling and spot welding. Recently performances of Nd:YAG have improved in terms of average power (1kW sources are now industrial

machines) and, apart from the advantage of optical fiber beam delivery, the possibility of pulse shaping offers a new degree of freedom to the metallurgical and welding engineer. Keeping constant the average power, peak power and pulse length can be selected in order to have the desired effect (fig. 4): for example high peak power and short pulse length are commonly used for efficient cutting, while lower peak power and longer pulse length ensures good quality welds. Even the distribution of energy during a single pulse can be optimized in order to obtain the best metallurgical structure (fig. 5).

These features make the use of Nd:YAG laser very appealing for structural medium thickness welding, especially for alloys having highly complex microstructure such as modern superalloys.

### **Cladding and reverse machining**

Laser cladding is a rather new technology to deposit material on damaged components [4]. Although attractive for the remachining of heat sensitive precipitation strengthened superalloys, up to now the essential parameters that identify the process aren't classified according international codes as for other welding process; moreover the correlation between parameters and results is too much system dependent.

Experimental tests showed dependance of the morfological properties mainly on absorbed laser power, laser spot dimension, advancing speed and powder feed rate. In fig. 6 the deposition rate achievable with 2 kW CO<sub>2</sub> laser is reported; different powder feed rate and spot dimensions have been used.

In fig. 7 the heat input  $E_i$  (J/mm) and the heat per unit volume of deposited material  $E_v$  (J/mm<sup>3</sup>) are reported; the parameters are similar to the above listed ones. Heat input is minimized using small size focal spot that allows, keeping constant the power density, to use lower laser power or, keeping constant the laser power, to increase power density using then higher advancing speed. With a wider focal spot it is possible to weld a greater amount of powder improving the deposited/sprayed powder ratio, increasing the process efficiency and minimizing  $E_v$ . Examples of Nd:YAG lasers used for cladding are very scarce: some special application with c.w. Nd:YAG is now entering in production.

### **Laser welding of IN738 superalloy**

The Ni-based superalloys are strengthened by a large volume fraction of stable precipitates. These are taken into solid solution within the HAZ associated with the welding process and rapidly reprecipitate during cooling, imparting very high strenght to the metal; the material is unable to tolerate welding stresses and cracks occur [5].

At present, a weaker weld metal is used to accomodate the welding stresses.

The problem of cracking becomes more severe for high heat input welding processes because greater accomodation is required [6].

It follows that such materials may exhibit greater weldability with a low heat input process, with a limited heat affected zone.

It is considered that the characteristics of CO<sub>2</sub>-laser, combined with a carefully chosen prewelding treatment and optimized welding parameters will lead to high integrity welds. In the following are presented welding processes performed with both Nd:YAG and CO<sub>2</sub> laser: Nd:YAG in pulsed mode with average power of 500 W and a c.w. fast axial flow CO<sub>2</sub> laser having 2 kW of maximum power.

### **Nd:YAG welding tests**

The process parameters were chosen in order to obtain the lowest heat input and the best surface quality of the welding; a pulse shape similar to fig. 5 has been programmed.

Ni-base IN738 superalloy has been used for welding tests, after a heat solution treatment at 1120° C for 2 hours in vacuum chamber.

A number of welding conditions have been investigated; the best ones are listed in tab. 1. The micrographic section (fig. 8) shows that cracks don't occur in HAZ, even if some grain boundary precipitates (fig. 9) are present where generally cracks start from. It is also possible to observe the pulsed mode effect that generates different solidification fronts (fig. 8).

**TABLE 1 - Superalloy penetration test by Nd:YAG**

Pulse time	ms	7.5
Repetition rate	Hz	20
Average power	W	300
Speed	mm/'	200
Gas flow	NI/'	Ar 30
Peak power	kW	2
Pulse energy	J	15
Material conditions		sol. ami.

### **CO<sub>2</sub> c.w. welding tests**

In these tests the process parameters reported in tab. 2 have been used. Advancing speed values, lower than 2.2 m/min, generate the typical cracks phenomena at grain boundaries in a HAZ.

**TABLE 2 - Superalloy penetration test by CO<sub>2</sub> c.w.**

Power	W	2000
Speed	mm/'	2200
Axial gas flow	NI/'	Ar 20

These parameters allow to obtain good high penetrating weldings without cracks. The weld zone microhardness is similar to the base material's. However the cracks formation is strongly related to the presence of large primary carbides; a medium temperature pre-heating can be convenient when extensive carbides dissolution is not possible.

### **Laser cladding tests**

The cladding tests have been carried out using a fast axial flow 2 kW CO<sub>2</sub> laser.

The process parameters were chosen in order to obtain a good metallurgical bonding to the substrate, a satisfactory surface aspect and the highest deposition efficiency, very important in reverse machining.

The Co-base superalloy powder used as cladding material is the AMDRY X40 having granulometry between 20 and 45  $\mu\text{m}$ .

The cladding tests were aimed at vane feather seals build up, that were service exposed; typical repairing with automatic GTAW device is shown in fig. 10.

One of the vane component repaired with laser is pointed out in fig. 11.

The magnification of fig. 11 shows the metallurgical bonding of the cladding with the substrate crystals where the dendrites growth start from.

## Conclusions

Laser technics are able to repair damaged areas of high temperature components. In particular it is suitable for restoration of missing metal. The laser process produces welding characterized by low heat input and heat per unit volume of deposited material. Their values can be easily optimized in order to meet the specific application.

As far as microstructure is concerned, dendritic structure is typical of the cladding and metallurgical bonding between cladding and substrate is ensured. HAZ is very limited.

These good metallurgical features combined with the flexibility of laser "torch" shows the great potential of laser reverse machining. However an important limitation should be pointed out: laser cladding can't be a manual operation and thus enhanced flexibility of either workpiece or beam handler is required because of many different kind of damage.

It is known that other projects, now under development [7][8], are studying the possibility to introduce automatic measurement of the damage of gas turbine components.

The measurement phase is then followed by repairing with automatic GTAW or plasma welding. Substitution of these techniques with laser cladding could enlarge the field of application even to precipitation hardened Ni-base superalloys that exhibit low weldability with conventional welding techniques.

## References

- [1] V.P. Swaminathan, report GS6544, Electric Power Research Institute, Palo Alto, California, Nov. 1989.
- [2] K.H. Keienburg et al., *Mat. Sci. Tech.*, 1985, no 1:620.
- [3] R. Thamburaj et al., *Int. Met. Rev.*, 1983, no 1:28.
- [4] P. Mehta et al., Proc. Int. Conf. ICALEO '84, Toledo, Ohio, 1984.
- [5] C.T. Sims, *Superalloys II*, (New York, N.Y.: John Wiley & Sons, 1987).
- [6] W. Cerri et al., Proc. Int. Conf. LIM 4, Paris, 1986.
- [7] G. Malone, *Weld. Journal*, 1989, no 6.
- [8] BRITE Project P-2068-3, CEE Dir. XII, Bruxelles, 1988.

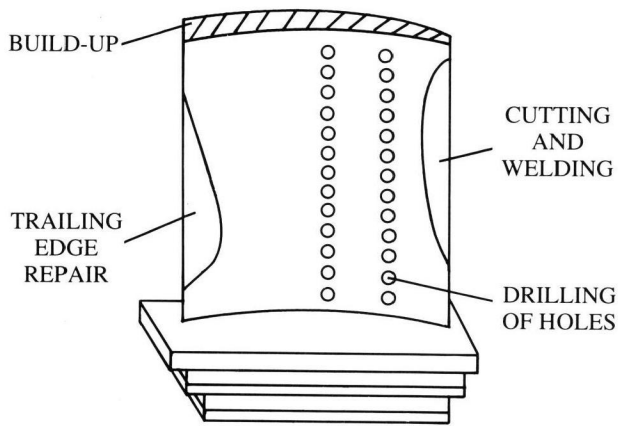

Fig. 1:

Applications of lasers in turbine repairing include damaged sectors cutting and welding of new inserts, tips, labyrinth seals and knife edges build-up, opening of cooling holes in repaired airfoils.

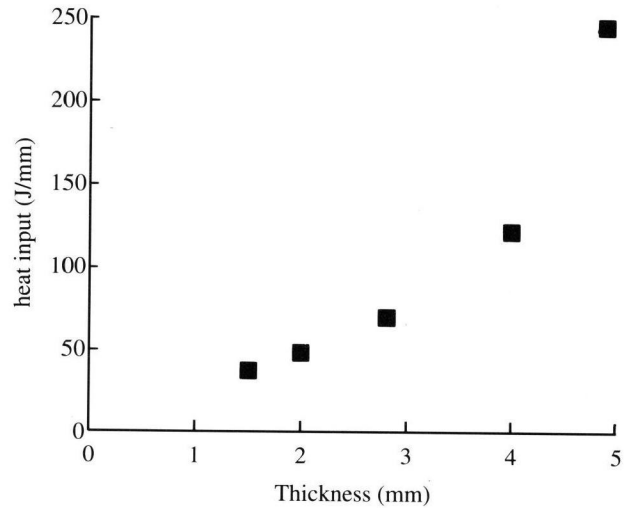

Fig. 2:

Heat input associated to laser welding: experimental data refer to 2 kW CO<sub>2</sub> fast axial flow laser focussed with 5" ZnSe lens.

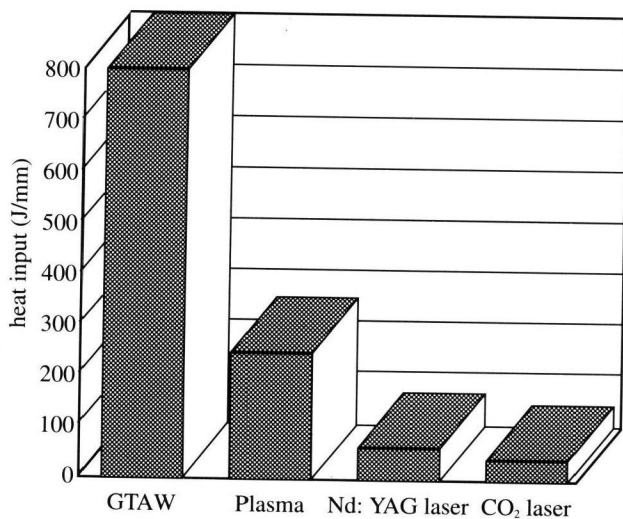

Fig. 3:

Values of heat input associated to various welding techniques in welding applications. 2 mm thick welding without filler metal is considered.

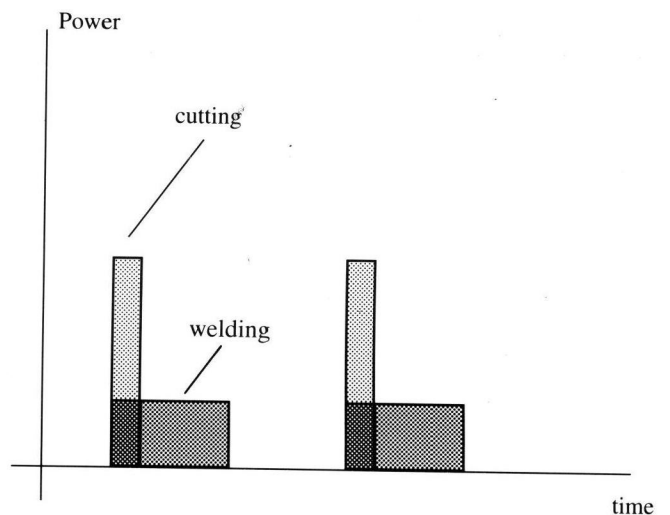

Fig. 4:

In applications of Nd:YAG lasers peak power and pulse length can be optimized.

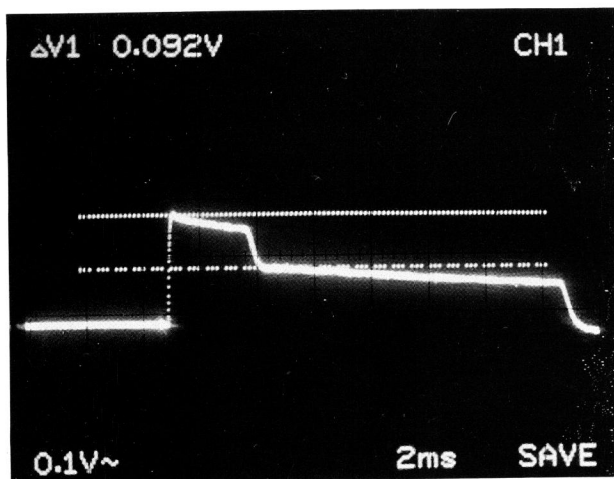

Fig. 5:

Shape of a single pulse optimized for 2 mm-tick welding: the first part ensures high penetration while the long tail gives gradual solidification of the single spot.

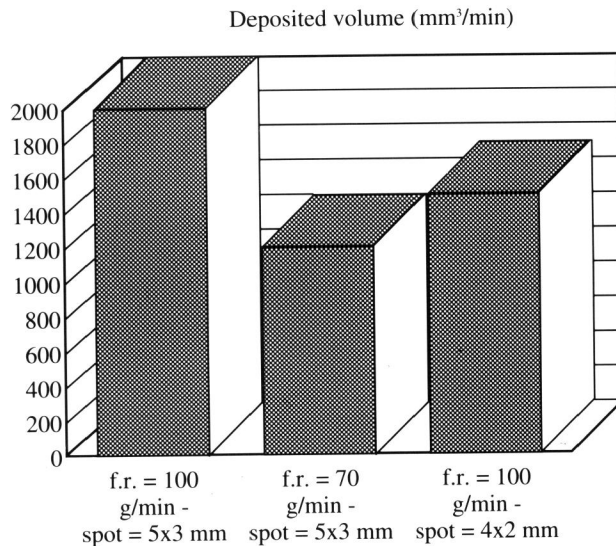

Fig. 6:

Productivity of laser cladding with 2 kW CO<sub>2</sub> laser: larger spots ensure higher productivity but entail higher heat input.

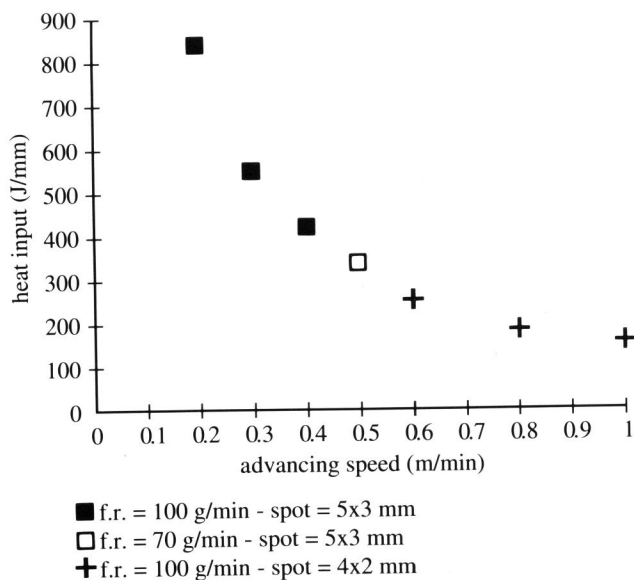
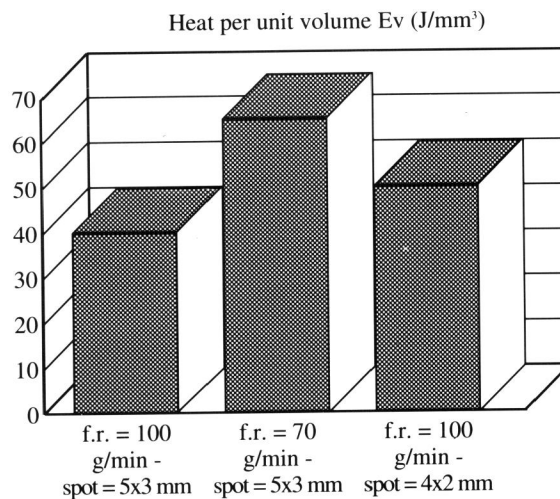

Fig. 7:

Heat input and energy per volume associated with laser cladding with 2 kW CO<sub>2</sub> laser; a) heat input: larger spot dimensions mean low laser power density thus low speed and high heat input; b) energy per volume of deposited material: the process is more efficient with high feed rate; the effect of different spot dimension could probably be overcome optimizing powder nozzle geometry.



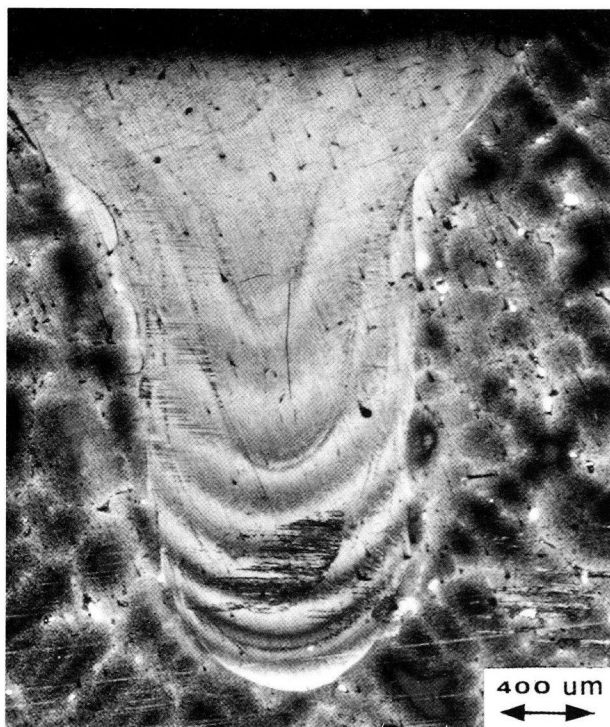

Fig. 8:  
Nd:YAG welding test



Fig. 9:  
Micrographic section of HAZ

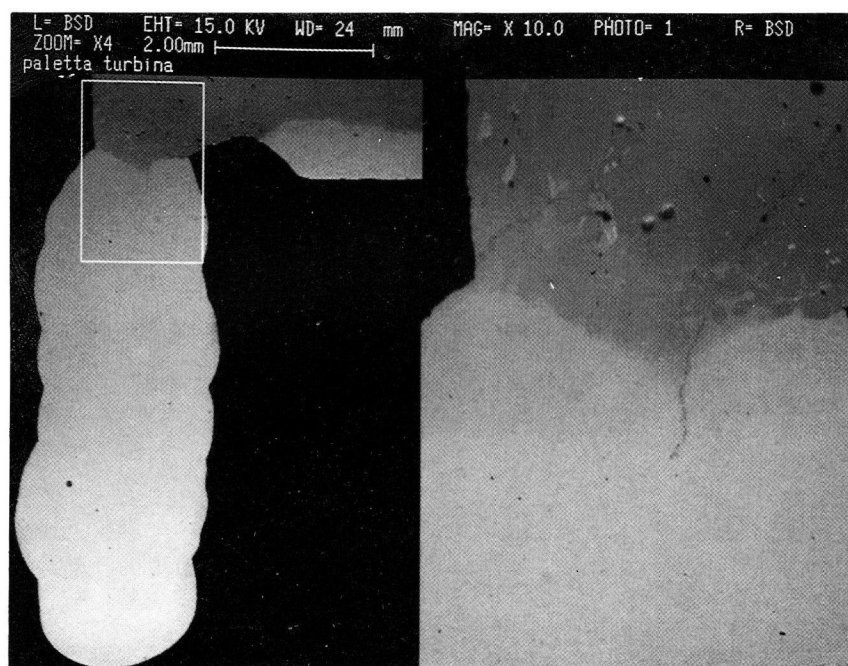

Fig. 10:  
SEM micrography of a GTAW vane reappear

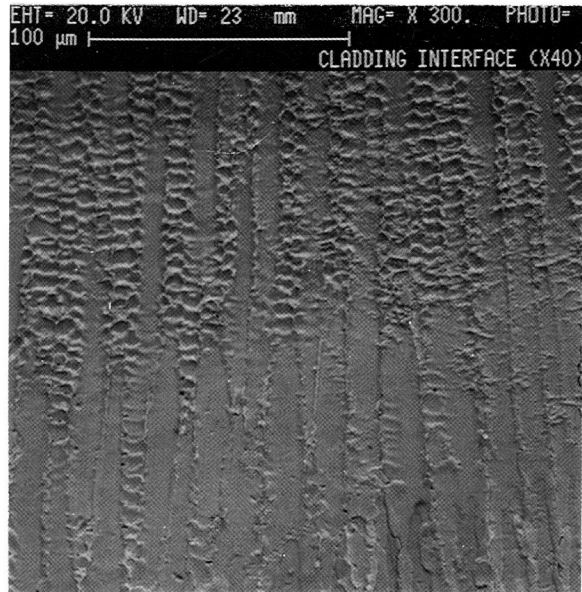
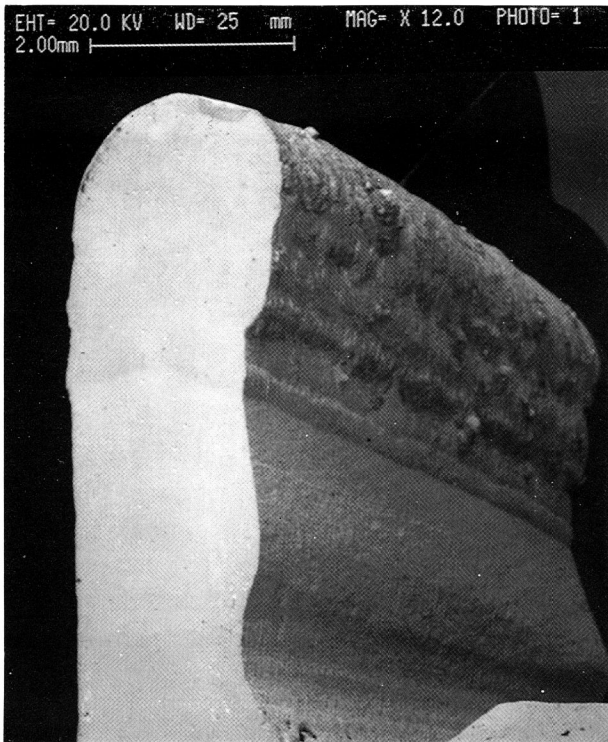

Fig. 11:

- a) Laser build - up of X40 vane
- b) Magnification of HAZ.