

Moulding of iron castings with evaporative polystyrene foam patterns immersed in loose sand: prospects and problems

C.A. GORIA and G. DEL GAUDIO, Teksid S.p.A., Divisione Fonderie Ghisa - CASTEK
G. CAIRONI and G. SILVA, Dipartimento di Chimica-Fisica Applicata, Politecnico di Milano
M. SELLI, Fata European Group S.p.A.

Abstract

The innovative moulding process described in this paper makes use of evaporative polystyrene foam patterns embedded in loose sand. It appears capable of offering considerable economic and technological advantages when compared with conventional casting processes. There are, however, a large number of problems and critical aspects surrounding the translation of its theoretical concepts, and the results achieved in the laboratory, into devices and specific procedures suitable for its application in high-volume production. Experimental testing on a pre-industrial scale of the solutions proposed with regard to the plant required and the process to be adopted is at an advanced stage. Whether or not the process itself will prove economical and feasible on an industrial scale, however, must be determined from the manufacture of sufficiently large batches using fully integrated, automated equipment.

Riassunto

Il processo innovativo di formatura e colata di getti in ghisa con modelli di polistirene a perdere immersi in sabbia sciolta, descritto in questo lavoro, sembra offrire, rispetto ai processi convenzionali, vantaggi economici e tecnologici importanti. Il lavoro di traduzione dei concetti teorici e delle esperienze di laboratorio in dispositivi e specifiche adatti alla produzione industriale di grande serie è però ricco di problematiche e criticità. Verifiche sperimentali, su scala pre-industriale, delle soluzioni impiantistiche e di processo sono in fase avanzata, ma solo la produzione di lotti sufficientemente estesi e con mezzi integralmente meccanizzati e automatizzati potrà dare una risposta definitiva circa l'economicità e la fattibilità industriale del processo.

Introduction

In recent years, Castek, the Ironfounding Division of Teksid S.p.A., has been developing for use in large-scale production, an innovative moulding process based on the use of polystyrene foam or expanded polystyrene (EPS) patterns immersed in loose sand, i.e. without any type of binder. This process, known as the "Policast" process, is similar to others already known for some time and described in the literature under various names: "Lost foam", "Full mold", "Evaporative pattern casting", etc. Like these, it is based on the use of evaporative EPS patterns but it differs in some of the specific solutions adopted at various stages of the process.

The principle on which it is based is simple: it is necessary to make an EPS pattern which gives a positive reproduction of the shape and dimensions of the object which is to be obtained by melting, taking account, of course, of the metal shrinkage during cooling; the pattern must be equipped with feeding gates and runners, these also being in EPS; the assembly consisting of the pattern and running/feeding system is then immersed in loose sand, following a procedure designed to ensure that all the external and internal surfaces of the pattern are surrounded by the sand and that this is sufficiently compacted against the pattern itself; this is followed by the pouring of the molten metal, which gasifies, and completely replaces the polystyrene in the running/feeding system and in the pattern itself; finally, after sufficient time, the casting together with the running/feeding system can be extracted from the sand and cooled in air.

The differences compared with conventional processes

used at a foundry for mass production are considerable; no longer are there two permanent half-patterns which imprint into a mouldable material two half-shapes with sufficient cohesion and which, together, generate the cavity to be filled with molten metal; nor are there cores to obtain the cavities inside the casting.

There are, on the other hand, notable similarities to other processes: the very ancient process of "lost wax" melting, already known and applied 2000 years before Christ to produce art castings, and the recent process of precision moulding or "investment moulding".

In both cases, a pattern made in wax (or in resins which melt when heated) with its casting accessories, runners, gates, etc., is covered with refractory material capable of forming a sufficiently strong shell mould; the wax (or resin) is then melted by heating and removed to leave a cavity into which the metal can be poured.

In the "Policast" process the refractory shell mould surrounding the pattern does not consist of a material which is in itself rigid, but is loose sand which is given sufficient, but only temporary rigidity, simply by compacting; further, the evaporative pattern is not removed from the mould before casting, but is gradually vaporised as the molten metal enters.

The "full mold" process and its development

In 1958 H.F. Shroyer (1) patented an original moulding process named "Cavity-less Casting Mold" or "Full Mold Process", in which an expandable pattern was

used, obtained by machining from an EPS block surrounded by foundry sand or another coldsetting sand/binder mixture. The pattern was connected to the outside surface of the moulding material by means of a feeding system, also in EPS, and by highly efficient vent holes to remove the gas produced, during casting, by decomposition of the foam material. With this process, proposed in particular for production of single castings or very limited series, such as base plates for machine tools, sheet press dies and similar products, it was possible to save on the high costs involved in making a permanent non-reusable wood pattern. The advance of the process was greatly helped, particularly in Europe, by Prof. A. Wittmoser who, in 1962, began a huge investigation project which led to considerable improvements in the foam product, the moulding materials and systems, and insights into the running and feeding of castings. Today numerous foundries throughout the world are joined together in the International Association of Users of the Full Mold Process, with the aim of co-ordinating and disseminating new knowledge on the methods, applications and results obtained.

The possibility of using loose sand as material for surrounding the pattern was first mentioned in a publication in 1962 (2) in which the author, A. Duca, reported that two investigators, H.B. Dietert and T.R. Smith, had obtained some noteworthy results in the laboratory when using sand in their tests; in 1964, two British investigators, Butler and Pope (3), published an accurate and detailed study on the production of castings in various metals obtained with good dimensional accuracy when using EPS patterns immersed in loose sand, and they also described the critical state of the process.

It was only in the second half of the '70s, however, after the energy crisis and the resultant economic crisis, that large industrial works, particularly in the automobile engineering sector, began to consider the full mould processes using EPS models in view of the savings in terms of production and investment costs which this type of process seems to offer, and with the intention of translating the laboratory ideas and investigations into processes suitable for large-scale industrial production of components with stringent requirements in relation to performance and dimensional accuracy.

The stages of the "Policast" process

A) Making the pattern and the cluster

The pattern cannot be produced on an industrial scale by machining from foam blocks.

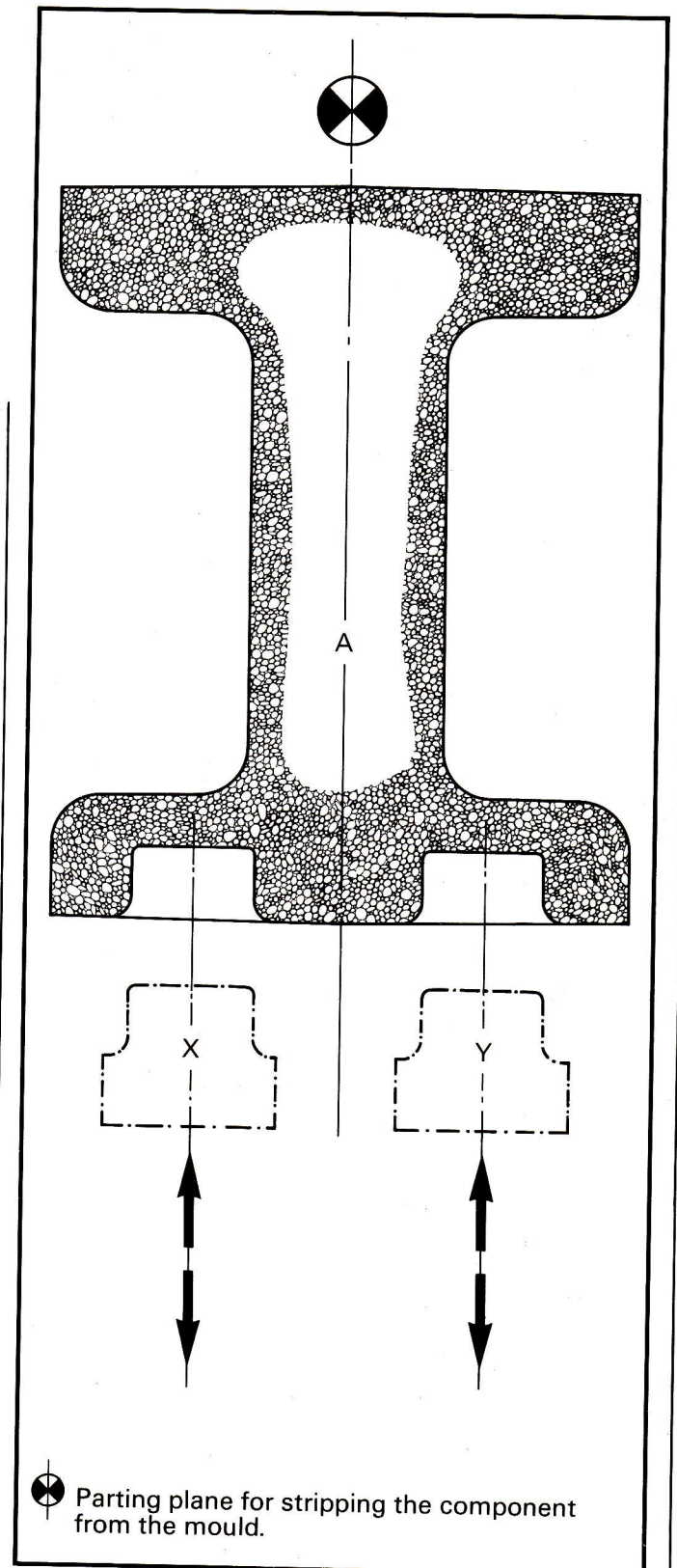

Fig. 1a - Component obtainable in 1 moulded piece (A) using movable plugs (X-Y).

Pattern-making by this method, which is suitable for the production of individual castings or prototypes, takes an extremely long time, and leads to porous crumbling surfaces resulting in castings with poor surface quality.

The only way therefore to obtain patterns of acceptable quality and at the right productivity level for mass production is by moulding.

Except in relatively rare cases, the pattern cannot be

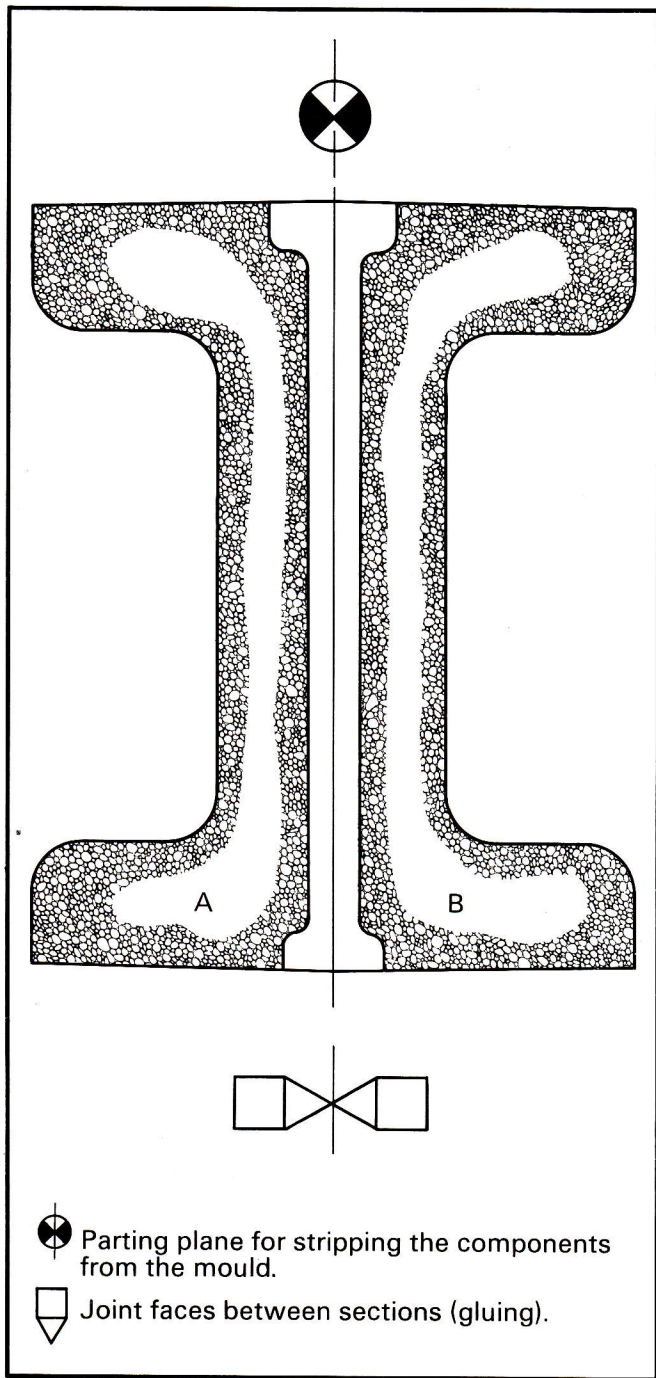

Fig. 1b - Component obtainable in 2 moulded sections (A-B).

obtained in one piece which can be stripped from the mould, because of the presence of undercut surfaces: in some cases, this can be avoided by using movable plugs inside the mould but, most often, it is necessary to try to find a way of subdividing the pattern into a number of parts which can, in turn, be stripped from the mould (Figs. 1a, 1b, 1c).

Having defined the parts into which the pattern is to be subdivided, the corresponding moulds are prepared which, except for the greater dimensional accuracy required by the mechanical engineering industry for which the final castings are intended, are made in accordance with the specific procedures of expanded polystyrene moulding technology.

Each part or "slice" requires two half-moulds or shaped loose pieces, one to obtain the outer parts (female) and one to obtain the inner parts (male) (Fig. 2). The various half-moulds constitute as many inserts

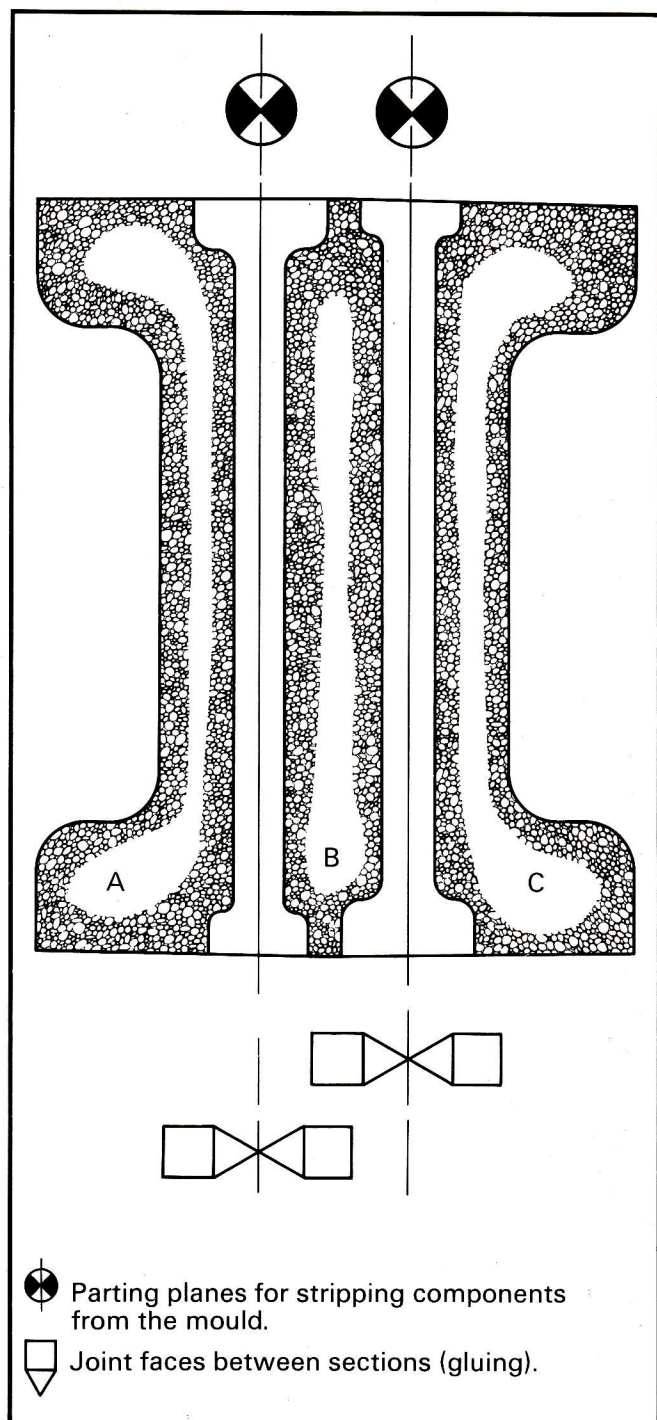

Fig. 1c - Component obtainable in 3 moulded sections (A-B-C).

which are fixed to a plate of suitable dimensions on the moulding machine.

The cycle consists in a preliminary phase in which the polystyrene granules in the as-received state, with an apparent density of 600 - 700 g/l, are brought into contact, in suitable vessels known as pre-expanders, with steam at 110 - 120°C which, giving up heat to the granules, softens them and dilates the blowing fluid which they contain. Pre-expansion is continued until the required apparent density is reached which, in our case, is normally 15 - 30 g/l: there is therefore a 20 x to 50 x increase in volume compared with the material as received (Fig. 3).

The pre-expanded material, after drying, is charged into a hopper, mounted on a machine by which it is sucked from the hopper through injectors working on the

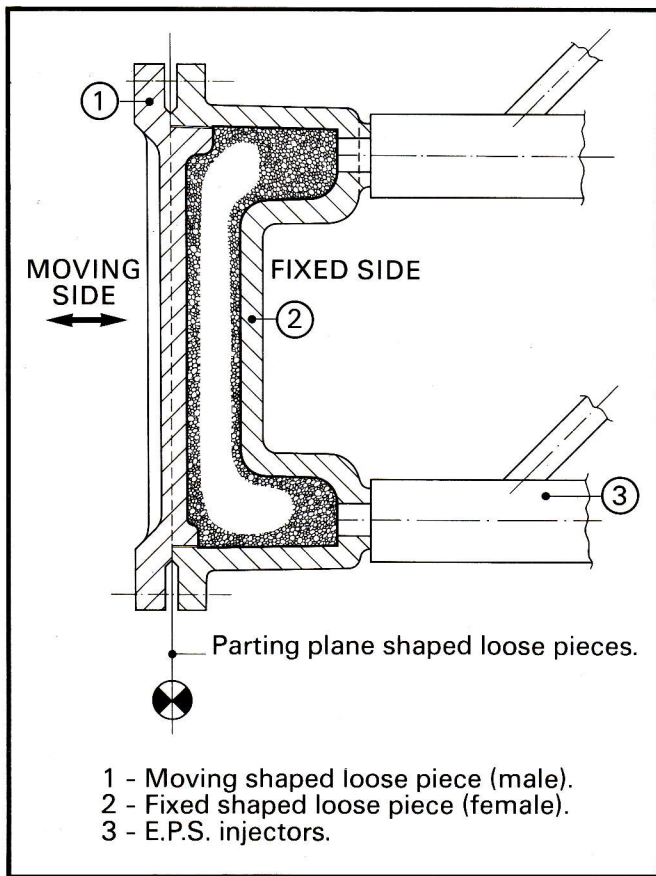

Fig. 2 - Schematic diagram of the pressing operation.

principle of a Venturi tube, and "blown" into the mould. For complete regular filling it is necessary to have numerous small holes or pieces of wire gauze on the surface of the shaped loose pieces through which air can be evacuated without any polystyrene escaping. Through the same holes a flow of steam is then passed through the mould at 110 - 120°C, so that the heat from this steam causes further swelling of the polystyrene and the granules weld together due to incipient surface melting: after this stage, known as "cooking" and representing the moulding process proper, not only is the hollow part of the mould completely filled with polystyrene, but every void space between the granules is also completely filled up. The last stage is cooling the mould by means of a fine water spray to bring the temperature of the moulded product to 40 - 50°C, when it can be extracted without risk of deformation due to inadequate dimensional stability. Pattern accessories, i.e. runners and gates, are also moulded by the same process.

At this point, all the slices of the pattern are assembled to form the complete pattern, and a number of patterns, in a configuration previously studied and tested, are connected by the gates to the runners and feeding stick in order to form the cluster for casting (Fig. 4).

The joints must be made using a glue with procedures which ensure, with sufficient speed, complete adhesion of the joint planes so that the various parts are firmly joined together in all the operations which precede pouring; it is also necessary to achieve perfect sealing of the joint planes to prevent the sand and in particular the mould coat of which we shall speak later,

Fig. 3 - Diagram showing sequence of operations for converting polystyrene into fabricated products (EPS).

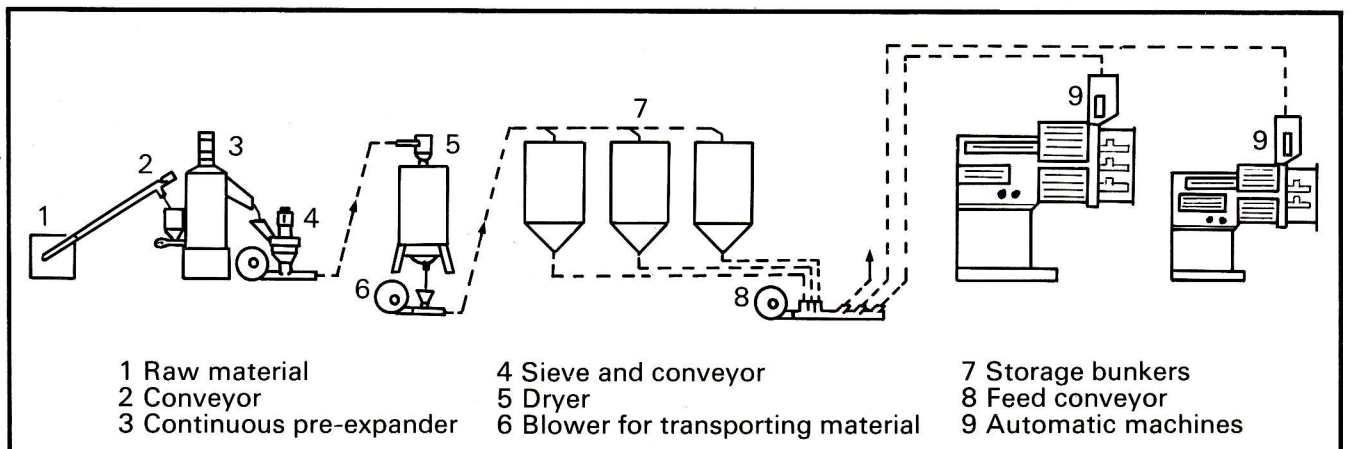

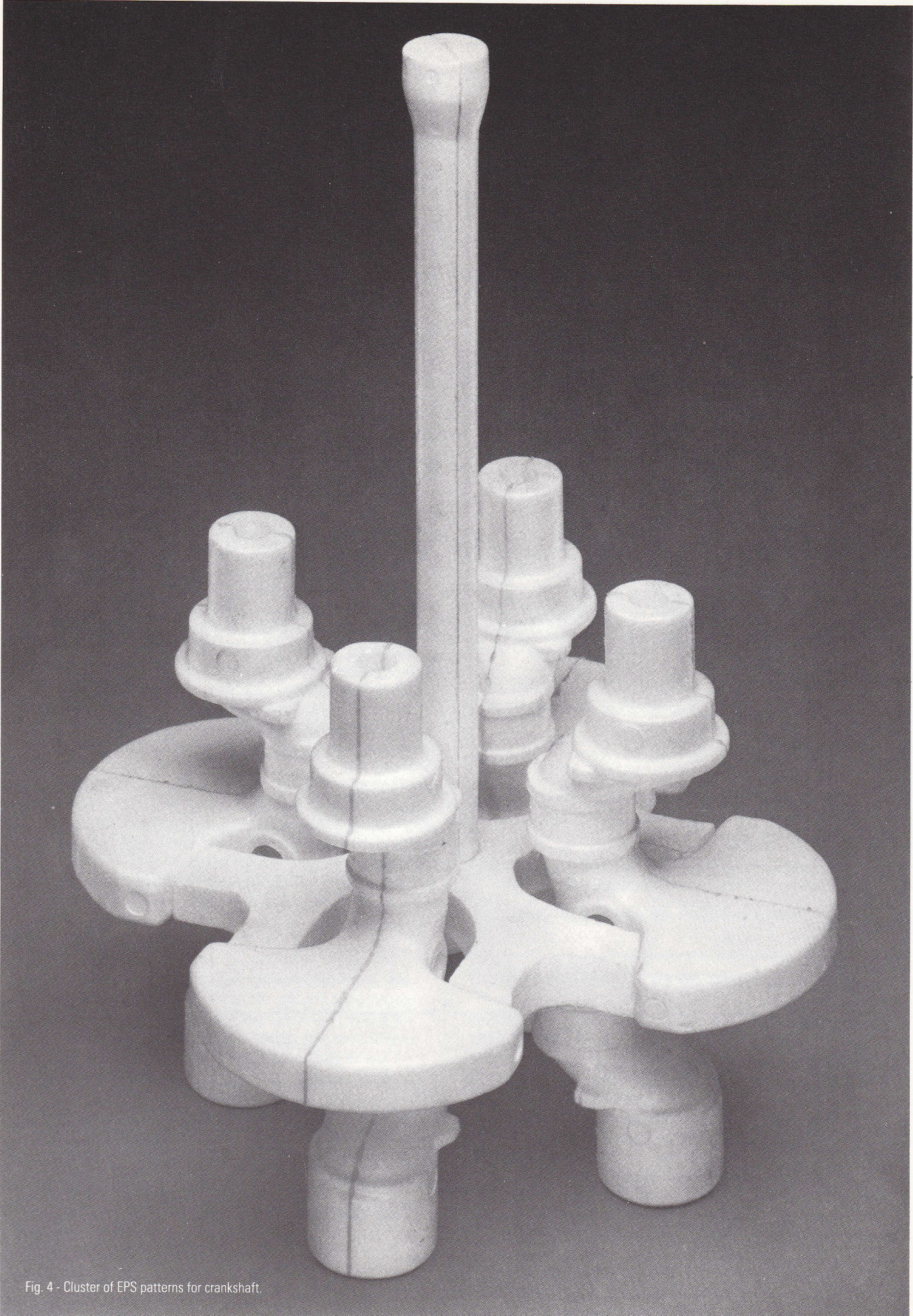

Fig. 4 - Cluster of EPS patterns for crankshaft.

from penetrating inside and being incorporated in the metal.

B) Preparations for casting

Before the stages of covering it with sand and pouring, the assembled cluster must be treated by wash coating in order to cover the polystyrene with a thin porous refractory film. This treatment is absolutely essential for the surface quality of castings and to control the gas removal rate, as will be explained later. The product used is similar to the wash coating generally employed in conventional processes, particularly in core preparation; it consists of a refractory pigment, in fine powder form: quartz, alumina, chromite, zircon or similar; a dispersant to keep the refractory particles in suspension; an organic binder to give the refractory particles a sufficient degree of cohesion after drying; thixotropic agents to give the rheological properties necessary to guarantee that a uniform thickness is applied; and finally, a carrier which may be water, methyl alcohol or ethyl alcohol.

After the coat has been dried in an air flow, possibly warm (40 - 50°C), the cluster is placed in a container and loose sand is poured round it by gravity, taking due precautions. The sand should be of medium particle size: sand which is too fine does not allow rapid removal of the gas during pouring, whereas a sand which is too coarse gives castings of poor surface appearance. A size distribution with a distinct predominance of material retained on a single sieve with no fines is the most suitable; the preferred particle shape is roundish, or at any rate with rounded edges, which gives the sand greater fluidity and thus facilitates the operations of immersion in the sand and compaction; on the other hand, its refractoriness is not particularly critical, even for iron castings. One sand used by us with SiO₂ ≥ 85% and an AFA fineness index of 35 - 40 has given more than satisfactory results. When the pattern cluster has been buried in the sand, compacting is carried out by vibrating the container. The frequency, amplitude and intensity of vibration, the direction of the movement imparted, the shape of the container and the point at which vibration is applied are highly critical factors in the process as regards the acceptability of the final castings with respect to dimensional accuracy.

C) Casting, extraction of the clusters and sand recycling

The container, after the sand has been compacted, is taken to the casting station. The flared end of the sprue rises slightly above the free surface of the sand, and above it is placed a pouring

bush designed to make all the liquid iron flow together at that point. When poured, the metal goes down the sprue, runners and gates to reach the pattern. The mechanism by which the polystyrene is replaced with the liquid metal is quite complex, but can be summarised as follows: while the metal advances the polystyrene evaporates, partly by direct contact but mainly by radiation; there is therefore a liquid metal front advancing and a solid polystyrene front retreating; between these two fronts there is a space occupied by the gases produced by the polystyrene, and the sand, no longer supported by the latter and not yet supported by the metal, may collapse into the cavities or be fluidised by the compressed gases. To avoid both of these risks the cluster of polystyrene patterns is previously painted with a coating designed to support the compacted sand, with the gas pressure exerted from inside, for the time necessary for the metal to take the place of the polystyrene. It is therefore essential to achieve the optimum balance between the permeability and mechanical strength of the coat layer. During the period of casting and solidification there is therefore no direct contact between the iron and sand; most of the thermal stress is therefore taken up by the refractory constituent in the coat, with which the grafitic carbon produced in considerable quantity during decomposition of the EPS in the absence of air and deposited on the paint itself acts synergically (Fig. 5), (4).

Analyses of samples of paint residues taken from the cluster, extracted after solidification, have revealed the presence of grafitic carbon contents of the order of 8 - 10%.

For correct casting it is necessary to bear in mind two important constraints:

- it is necessary to cast at full flow from the very first moment to prevent even the smallest part of the sprue from burning instead of evaporating; in the event of combustion, the sand collapses and as a result the sprue is partly or completely blocked up;
- there must be no hesitancy or interruptions in pouring which, by delaying the inflow of metal to replace the polystyrene, leads to collapse of the sand and loss of the mould.

After not less than 15 minutes in the container, the castings, now solidified, can be extracted, for example by turning the container over on a grid; the cluster, which appears covered with an opaque coating of partly calcined coat, is completely emptied of the sand contained in the cavities, which easily flows out through the same openings through which it entered during the sand immersion compacting stage. While the complete cluster is sent for finishing operations the sand is completely recycled.

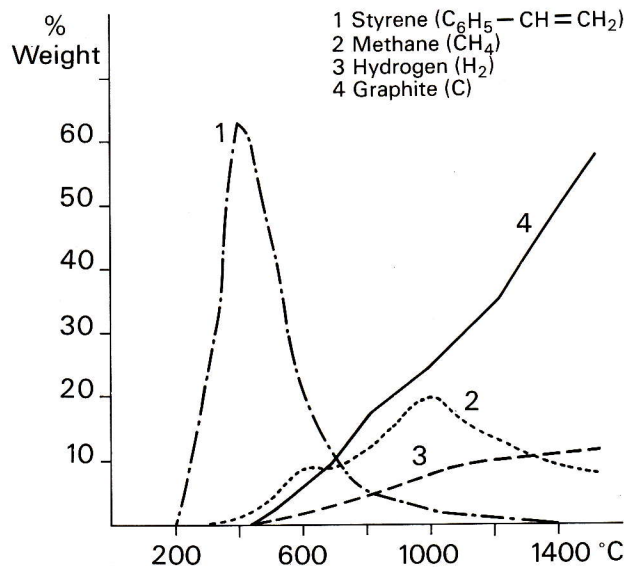
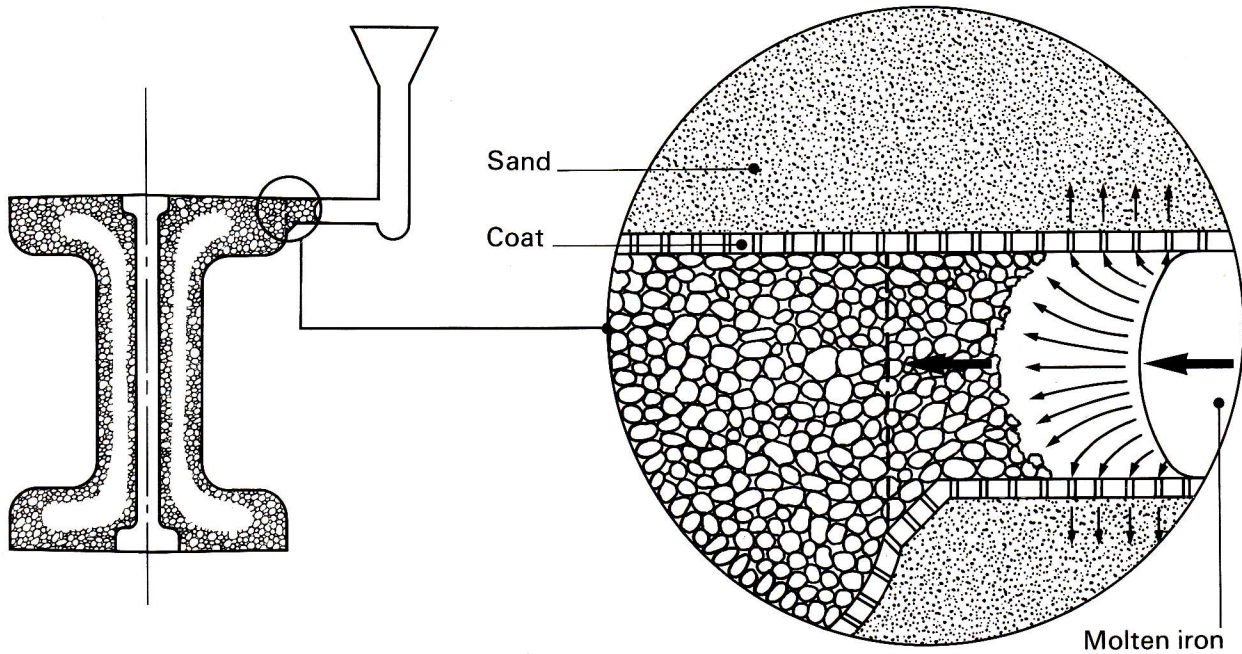

Fig. 5 - EPS evaporation during casting; dynamics and composition of pyrolysis products in function of temperature.

Most of the products of pyrolysis of polystyrene (4) are volatile and escape from the sand at the moment of casting and during the next few minutes; the heavier fractions condense in the direct vicinity of the casting; at the moment of turning over, when they come into contact with the air they burn off, so that the sand is automatically cleaned. The only reconditioning required for its re-use is to cool it by fluidisation with cold air while simultaneously removing the fines. In the case of iron castings, it was possible to verify that, even after hundreds of cycles always using the same sand, there is no increase in ignition loss, reduction of fluidity, or lump formation which raise any doubts about 100% re-use.

The last stage in the production cycle, which is common to any other foundry process, is finishing, which consists in separating the various castings from the running and feeding system, shot blasting and grinding off the gates. These are operations common to any foundry process but, in the case of the "Policast" process, some important differences must be specially mentioned; shot blasting is lighter, due to the absence of metal/mould reactions, and there is no defining operation since the mould in which the iron is cast, i.e. the cavity generated by evaporation of the foamed product, does not have any joint faces into which the metal can penetrate and form fins as it solidifies.

Comparison of the "Policast" process and the green sand process

Before making a comparison of the green sand moulding system and EPS patterns in loose sand it will be useful to make a brief reference to the main stages which characterise the former process.

A casting is produced by pouring molten metal into a cavity obtained in a "mould" by placing a suitable material firmly round a "pattern" equal in all respects to the casting except for the shrinkage in metal volume; the pattern is then extracted to allow subsequent uniform moulding.

The need to re-use the pattern means that it is obviously impossible to carry out in-the-round moulding in which the casting is divided into two halves, each of which must be imprinted in the mould by the corresponding pattern; the cavity into which the metal is cast is then obtained by joining two moulds together. When the casting has cavities which "cannot be stripped" or cannot be obtained in the direction in which the pattern is stripped, it is necessary to use "sand patterns" or cores appropriately placed in one or both moulds.

The material used for the mould is "foundry sand", a mixture of quartz sand, bentonite, water and coal dust which is prepared by suitable milling procedures to obtain the characteristics making it suitable for moulding: plasticity, for a perfect copy of the pattern, and compressibility to give denseness suitable for the required cohesion in the green state (Fig. 6).

During the milling operation the batch of sand and additions corresponding to layers of the mould next to the casting is integrated, these layers irreversibly losing the properties mentioned as a result of the temperatures reached after casting.

The sand is then sent to the moulding machine where it is charged into a container (a moulding box) encasing the pattern, adjusted and rammed by impact and/or vibration using a plate or set of ramming tools.

After the pattern has been extracted, thus also obtaining the cavities corresponding to the running/feeding system, the cores if any are placed in the mould assembly and the moulding box is joined together with the box providing the complementary mould.

The dimensions of the moulding box, that of the pattern and the extent of the running/feeding system are constraints as regards the number of pieces which can be obtained per cluster.

Any cores used are obtained by shooting into a mould (a core box) a mix of quartz sand, resin and catalyst, which hardens following polymerisation of the resin which occurs by heat input through the walls of the

mould or by gas injection. The mixture is produced, as in the case of sand, in grinding mills located upline from the shooter.

What has been stated clearly shows the main points of difference between this and the "Policast" process (Fig. 7).

In the case of the "Policast" process, the moulding material consists of untreated sand, i.e. without any additions and which, having natural rheological properties or such properties induced by vibration, can conform to the shape of the outer surface and open cavities of the pattern.

There is thus no need to produce the moulding material which, in a traditional line, involves the presence of numerous complex units.

As stated, the sand is prepared in grinding mills with associated systems for conveying and adding measured quantities of additions stored in suitable bunkers; systems for control of the prepared mixture; and systems for selection at the moulding machine; it is also necessary to have, upline from the latter, suitable equipment for removing the lumps which prevent agglomeration of the sand before use.

The moulding machine is extremely complex because of the numerous devices for regulating the pressure exerted by the ramming tools, the mechanisms for transfer and joining of moulding boxes, and conveyors which recycle the quantities of sand which are in excess of the volume of the moulding box.

In recycling the moulding material after pouring, it is also necessary to consider, upline from the grinding mills, the entire system for reconditioning by moistening and separation of the fines which requires considerable development of conveyors and complex extraction systems. What has been stated with reference to the quantities of sand to be produced, used and reconditioned means that, as regards plant engineering, the line is a complex of considerable magnitude.

It is then necessary to link up the moulding line with the area where the cores are fabricated which are used in the line: although not so extensive as the first, this certainly involves plant engineering of no less complexity.

If everything involved in control of product quality for sand and cores is taken into account, this gives a complete view of the system.

In a "Policast" moulding line, therefore, the simplification and trimming of plant engineering, the simple nature of the product quality control, and the reduced energy requirement open the horizon to a new concept of foundry technology.

The absence of additives for the sand, such as clay binders, means that there are no fractions of material

FORMATION OF TOP MOULDING BOX (COPE)

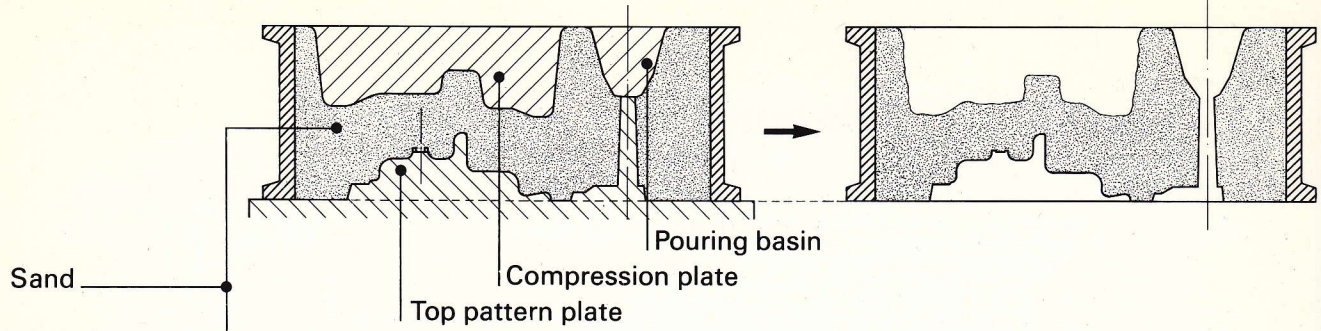

FORMATION OF BOTTOM MOULDING BOX (DRAG)

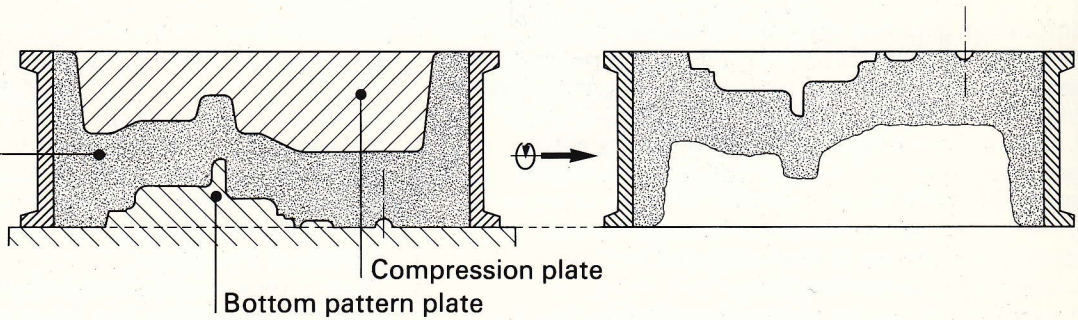

CORE MOULDING AND ASSEMBLY

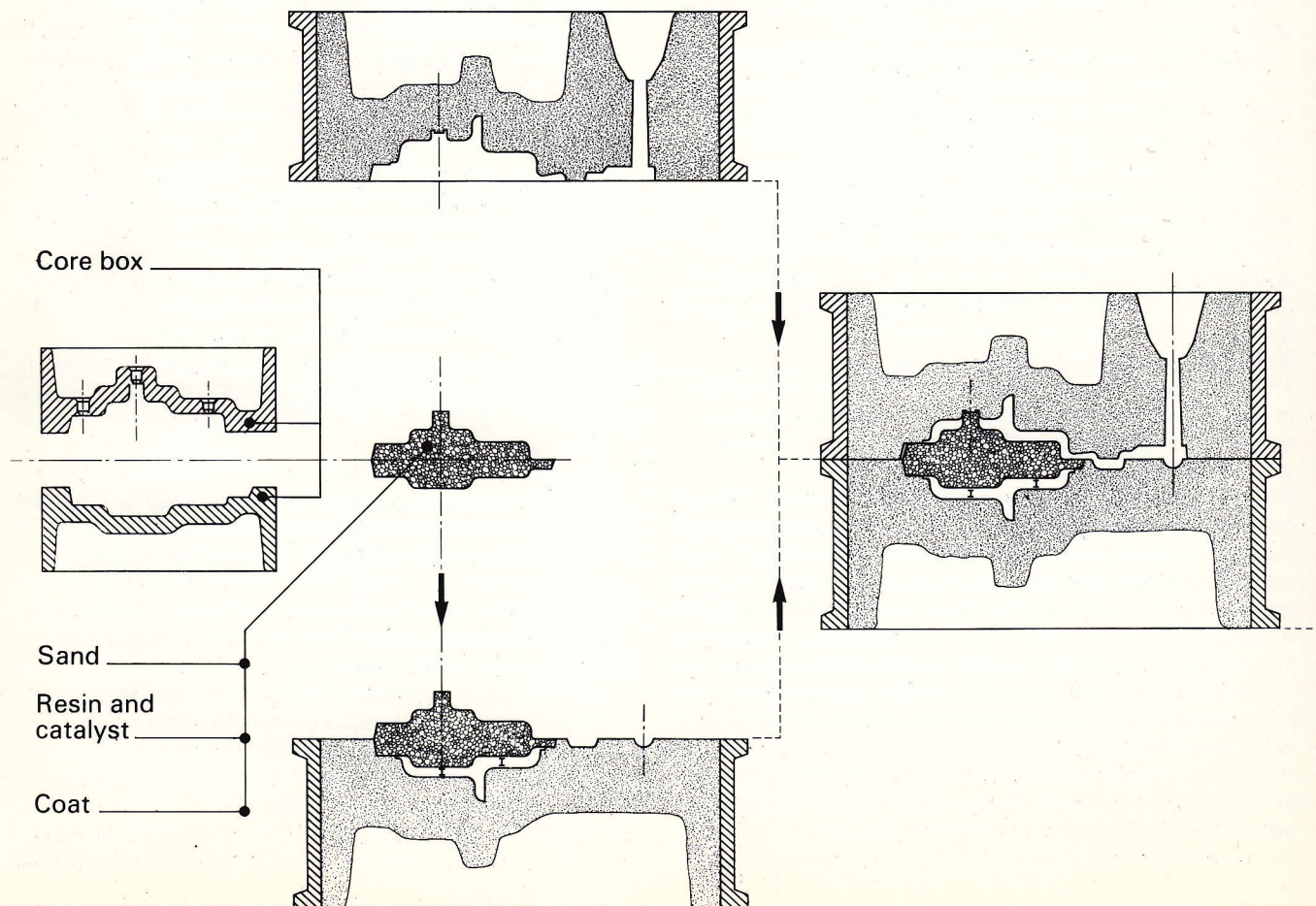

POURING AND SHAKEOUT

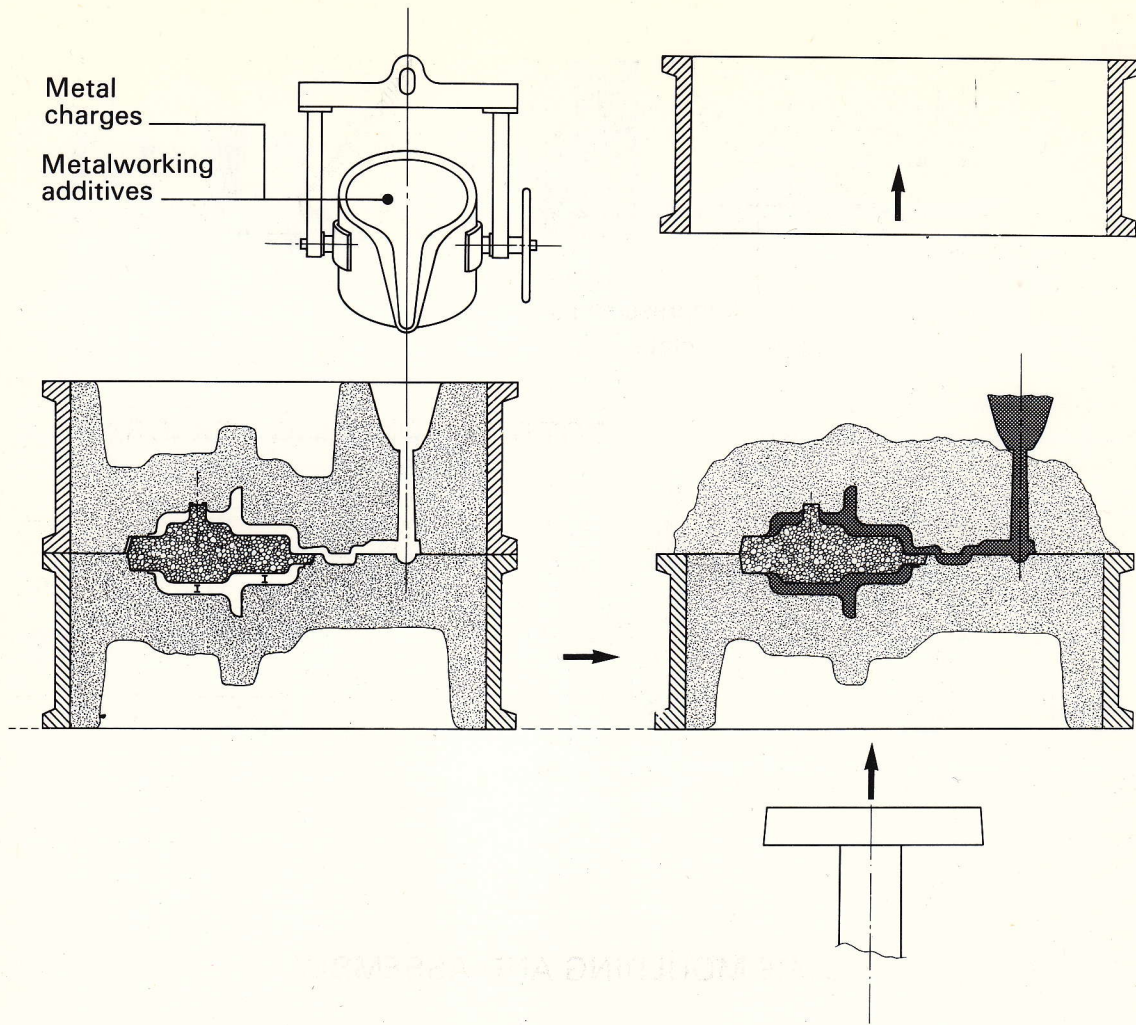
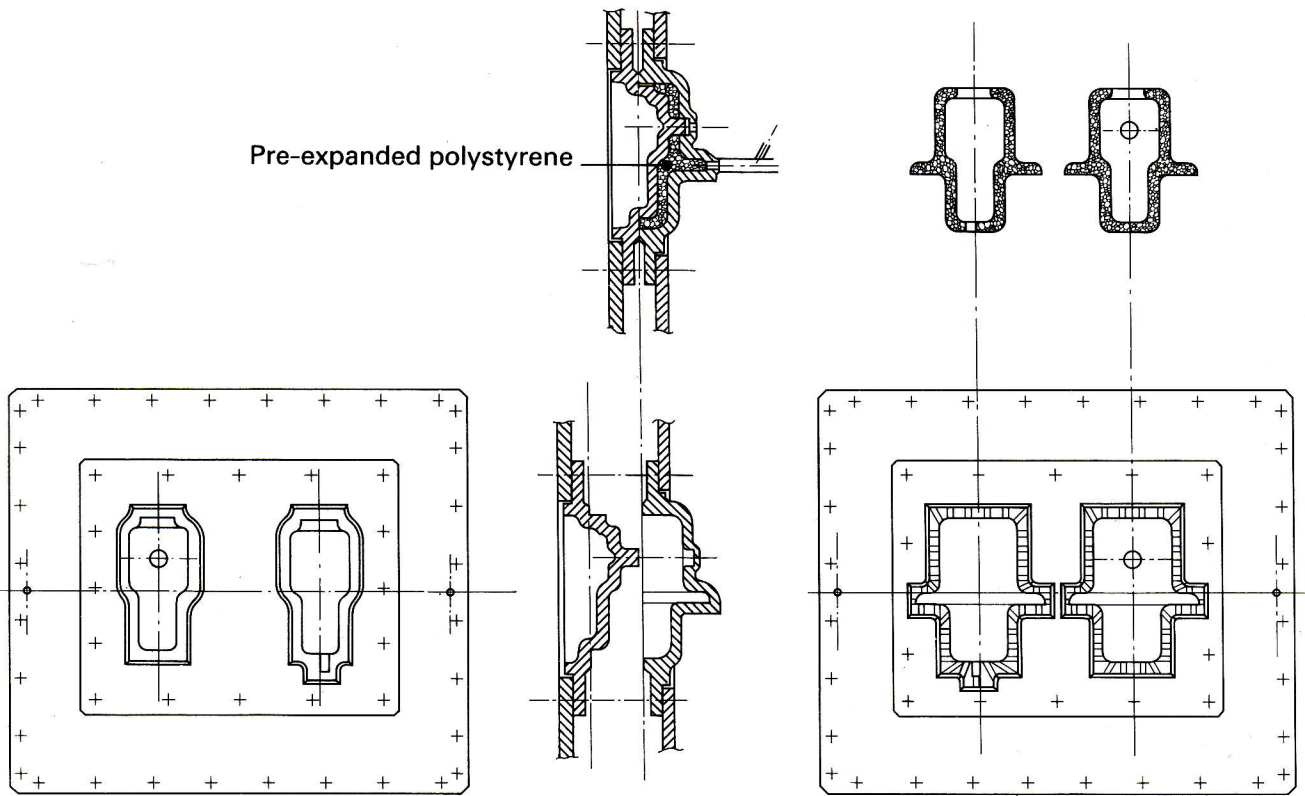

Fig. 6 - Core moulding and assembly, and casting sequence in a conventional process.

PRESSING

Pre-expanded polystyrene



ASSEMBLY AND PAINTING

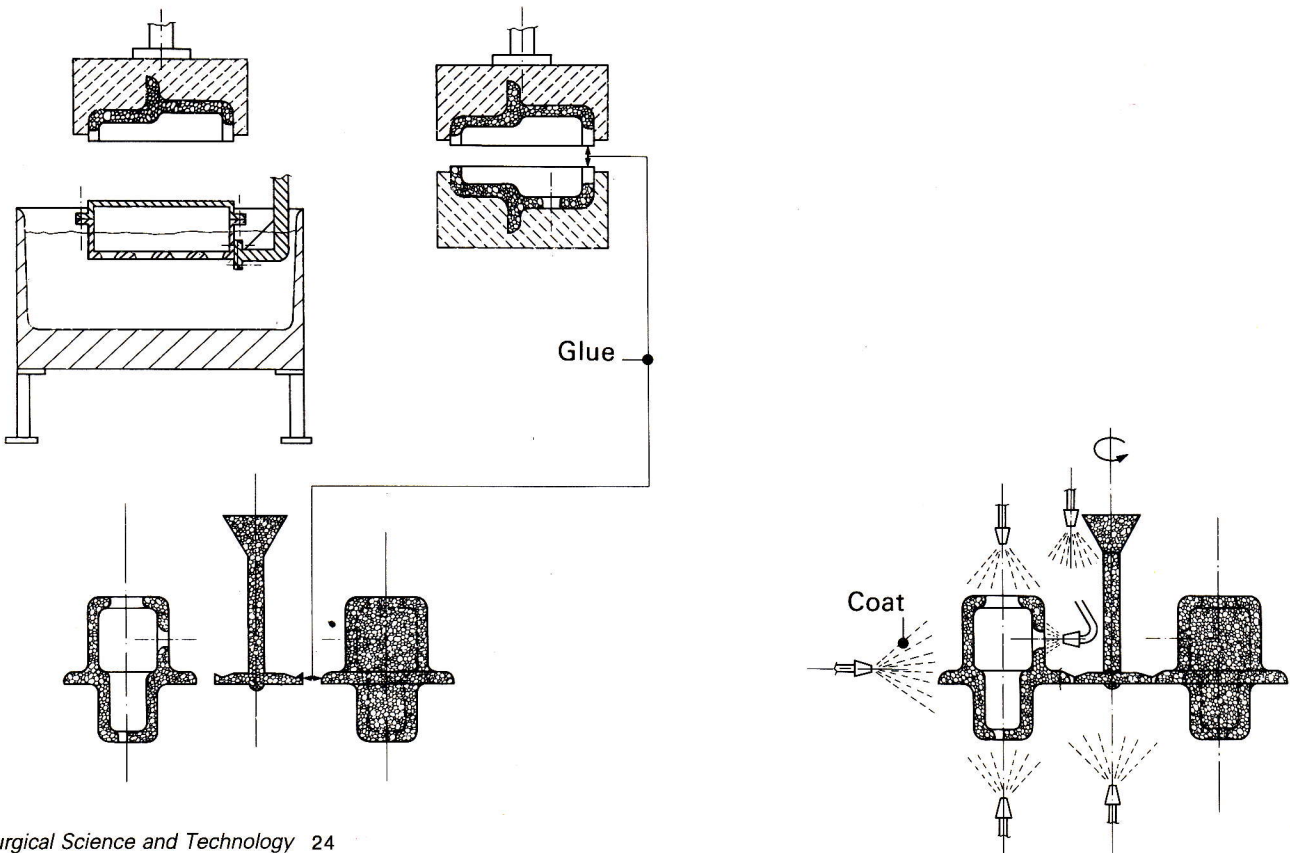

SANDING AND COMPACTION

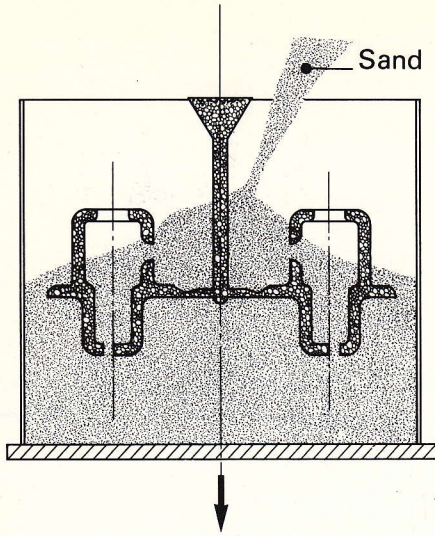

POURING

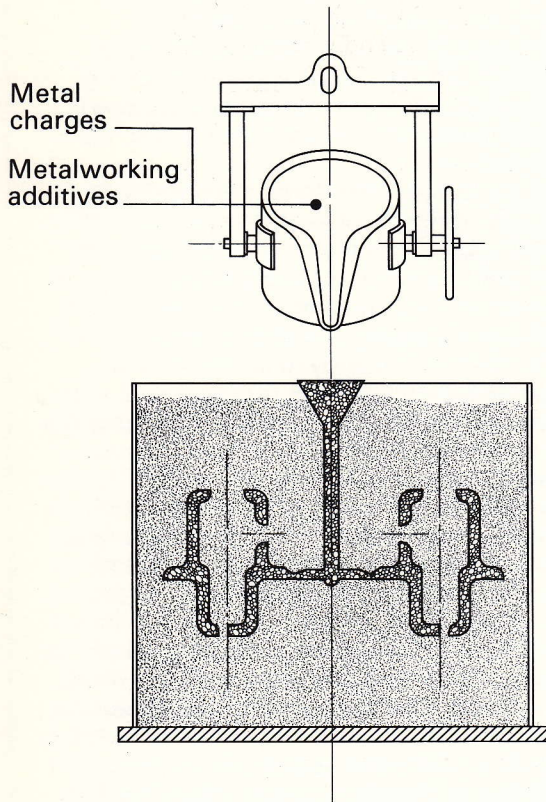
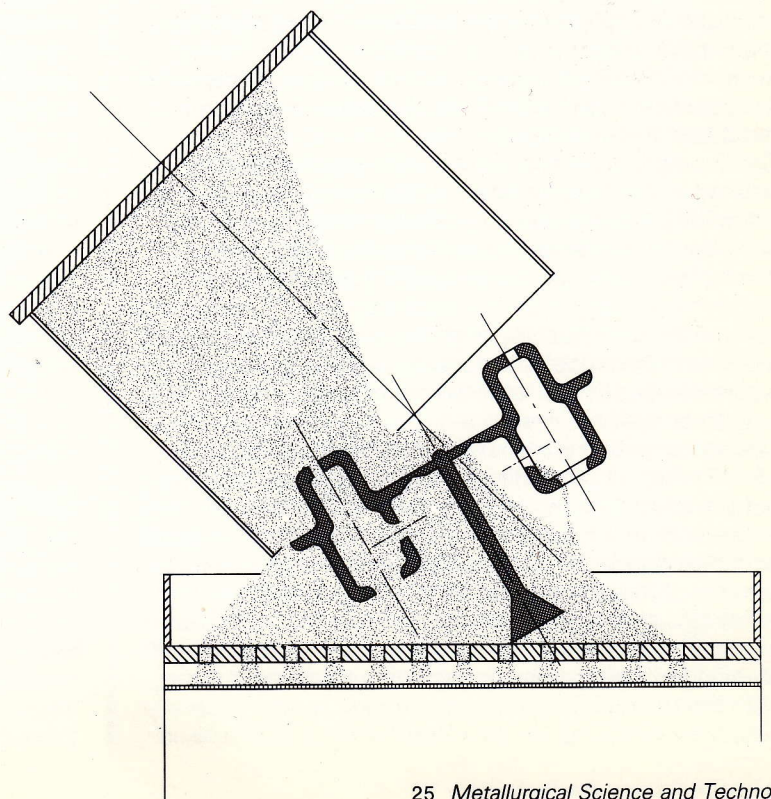

Fig. 7 - Moulding, pouring and sanding sequence in the Policast process.

WITHDRAWAL OF CASTING



subject to irreversible deterioration and, as the sand does not adhere to the casting, the moulding material is completely recycled after pouring. Further, as the quantities which constitute the core are also free of binders, this removes the problem, sometimes serious, on green sand moulding lines of removing core residues from the cavities of the casting and the mingling of sand and residues which, still carrying traces of binder, constitute a contaminant in the sand. Moulding by the "Policast" system is, however, a critical stage because it must be done according to procedures such that the sand conforms perfectly to the shape of the pattern, even in the remotest cavities, and becomes dense without deforming it. Deformation of the pattern when compacting has been carried out is irreversible and leads to a deviation of casting geometry.

The possibility of moulding "in the round" leads to two advantages in the Policast process compared with the traditional process. First, this eliminates casting defects due to imperfect joining of the two moulds and of the cores and moulds, resulting in misalignment of the half-shapes, changes in the thicknesses of plate parts obtained with cores, extended fins of excess thickness and partly broken moulds, with consequent sand dragging due to excessive interference between the core seat and print. It is also possible to design more rational feeding/running systems without the constraints imposed by the position of the patterns on the support plate.

In view of these advantages it is necessary to forgo the savings which can be achieved by using one pattern to mould a number of units.

Continuing this comparison, it will be noted that pouring in the Policast process is another delicate stage since the pattern must be replaced with the metal in accordance with a very specific law whereby the gas arising from vaporisation of the EPS can escape through the coat which covers the pattern, by a process compatible with stability of the mould. For this purpose it is essential to use an automatic pouring system which dispenses the required quantity of metal uniformly against time.

During the pour it is also necessary, for stability of the mould which is obviously not self-supporting, that the pattern should be replaced by the metal within the shortest time possible, which imposes the use of gates with a cross-section generally larger than necessary to cast the same component with a traditional system. Although, on the one hand, this means it is necessary to separate the castings from the cluster by cutting or breaking off the gates using specific equipment while, with the traditional system, separation is achieved simply by knocking, on the other hand it is possible, in

nearly all cases, to dispense with feeding devices (feeder heads) making up for the shrinkage in volume of the liquid metal, also in view of the sudden cooling of the metal during replacement of the EPS and the less extensive running/feeding system.

In the final analysis the foregoing leads to a distinct improvement in yield with obvious advantages in terms of energy requirement.

From the viewpoint of product quality a Policast casting has a better surface finish than a traditional casting due to the fact that, because of the presence of the interface consisting of the coat, there are no metal/mould interactions so that "subcutaneous" casting defects connected with these interactions disappear and the final roughness of the casting is equal to that of the moulded pattern.

As a result of the factors considered it is possible to reduce machining margins, or even do away with some machining operations, as in the case of through-holes for fixing with bolts. Since, in addition, when a Policast casting is extracted it is only covered with the residue of coat, less severe cleaning operations can be carried out, leading to savings in energy requirement and shot-blasting material.

A table is given hereunder which summarises what has been stated so far.

Concluding what has so far been presented and summarised in Table 1, it emerges that it is possible, by industrialisation of the "Policast" process, to achieve important advantages compared with conventional processes and, in particular, compared with the most widespread "green sand" process. These advantages are particularly clear in the moulding, pouring and finishing stages, i.e. in the production cycle, but those relating to the quality of castings produced, protection of the environment, and those which can be obtained in machining must not be neglected.

These can have tangible results in appreciable savings of materials, energy and the capital cost of foundry plant but also in the mechanical engineering industry where castings are used.

Problems of the "Policast" process

A) Redesign of as-moulded castings

By agreement with the customer, it may be necessary, in order to make the most of the advantages offered by the process, to carry out design modifications to the as-moulded castings as arranged for conventional moulding, in order to facilitate moulding of the pattern; the purpose of these modifications may be to reduce the number of "slices" to the minimum possible; to

TABLE 1 - Comparison of "Policast" process and "green" process

Stage	Advantages	Disadvantages
Moulding	Simplified plant engineering Elimination of additives in sand Elimination of cores Recycling of all sand	Patterns cannot be recycled
Pouring	Reduced consumption of liquid metal	Furnaces with automatic pouring required at the line Larger section casting gates
Finishing	Reduced abrasive shot consumption Elimination of de-finishing	Special equipment required to cut/break off gates
Quality	Elimination of misalignment Improved surface appearance	Possibility of shape defects due to deformation
Machining	Margins can be reduced The number of machining operations can be reduced	

locate openings at suitable points to facilitate entry of the sand into the pattern cavities during the sand immersion stage; and finally, simplification of the mould joint to facilitate the operations of gluing the slices together. It is also necessary to agree with the designer as regards the location of bosses corresponding to the holes for injection of the pre-foamed product, and seats for ejectors if required.

B) Moulding the pattern

This is a critical stage in the process, since the quality of the moulded product is exactly reproduced in that of the casting.

It is therefore necessary:

- to carry out correct cooling of the mould after "cooking" so that the EPS component is only extracted when dimensionally stable;
- to avoid deformation during extraction from the mould by assisting this operation, when it is difficult, with suitable mechanical ejectors;
- to position the injectors and venting gauze correctly in order to obtain uniform distribution of the prefoamed material in the mould and homogeneous cooking, even when there are considerable differences in the thickness of the moulded product; homogeneous cooking gives surfaces with no discontinuities and with clean edges;
- to use the smallest possible granules of pre-foamed material compatible with the apparent density of the final product which is in inverse proportion to the dimensions of the granules themselves; fine

material brings many advantages: denser surfaces, cleaner edges, increased rigidity; on the other hand, with finer material there is increased density and thus an increased quantity of gas produced during pouring; discontinuities in the pattern become surface defects or deep defects in the casting which adversely affect its mechanical strength in critical sections, or the hydraulic tightness of the cavities traversed by fluids; further, they may constitute points of paint penetration and lead to inclusions which also pass into the casting;

- to subject the slices to thermal conditioning so that the shrinkage in volume characteristic of EPS and due to evaporation of residual water during cooking and cooling, and of the expanding fluid, is achieved quickly.

Fig. 8 shows the percentage shrinkage in volume of EPS for a specific component as a function of the time elapsed after moulding, without thermal conditioning. The first section of the curve is mainly determined by loss of moisture, while the final section is determined by loss of expanding fluid. The shrinkage in volume of the EPS product, as well as being determined by the factors described, further depends on the following variables: *mass* - the greater the mass, the smaller the shrinkage; *ageing* - the greater the ageing of the raw material the smaller the shrinkage (beyond a certain degree of ageing, however, the material cannot be used for satisfactory moulding); *apparent density* - the greater the apparent density of the EPS the smaller the shrinkage.

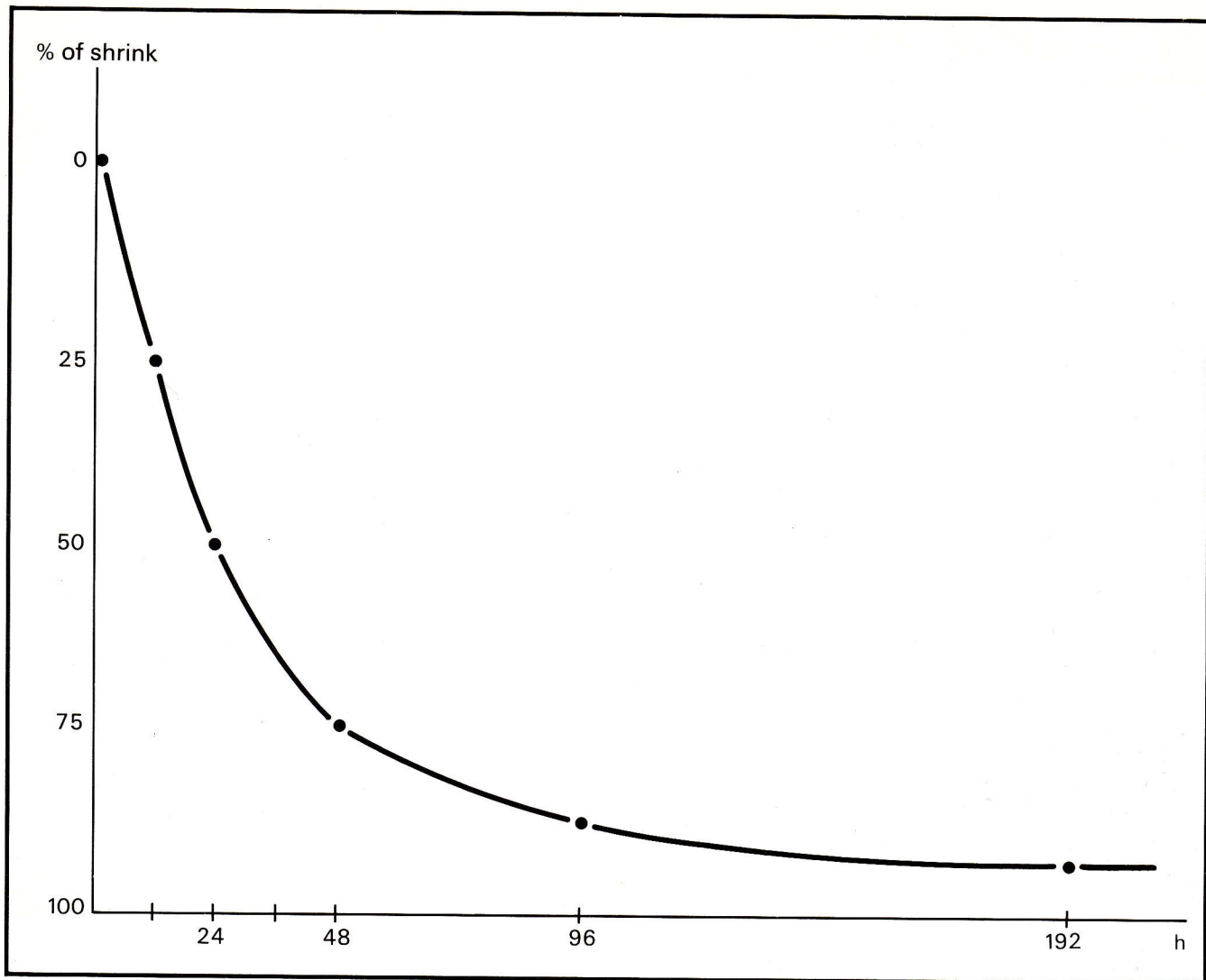

Fig. 8 - EPS shrinkage in function of post-pressing time.

C) Assembly

In assembling the slices to make up the patterns, and patterns in a cluster, it is not only necessary to obtain adequate adhesion of the components but, in particular, complete sealing of the outer and inner edges of the various joint faces in order to avert risk of penetration by refractory coat with consequent incorporation of heterogeneous material in the metal during pouring. In highly stressed components this type of defect is not permissible.

Fig. 9 - Paint penetration into pattern joint face.



Fig. 9 shows the effects of coat penetration inside the joint face of the pattern slices.

D) Coating

In addition to defects which may occur during coat application due to the porosity of the moulded product or incorrect assembly, others may arise due to insufficient or excessive application of the coat. An inadequate coating treatment leads to reduced thickness of the metal/sand interface, and consequently to the presence of encrustations (sand) in the lower parts of castings or mould yielding in the upper parts.

If the coating is too heavy this reduces the gas permeability during pouring, with consequent slowing of the metal as it replaces the EPS: there is then a risk of incomplete castings or castings with surface defects in the upper zones of the pattern, characterised by a particular appearance of the skin, which is wrinkled and glossy (Fig. 10).

E) Compaction

This is without doubt the most critical stage for geometric accuracy of the casting since, during this stage, the rheological properties of the sand generate movements of the latter relative to the cluster, which is therefore stressed by the thrust from the masses of



Fig. 10 - Veined appearance of surface due to coat with insufficient gas permeability.

sand in movement. Particular configurations of the cluster and pattern may accentuate the effect of this action and it is therefore necessary to prepare the cluster by assembling it, burying it in sand and compacting the sand by procedures which will minimise the above effects.

For this purpose it is necessary to make a prior study of the parameters and procedures by which the various operations which will lead to an adequate degree of compaction must be carried out. Teksid-Castek has therefore developed instrumented equipment to record the movements of the sand, the deformations caused and the degree of compaction of the mould.

Fig. 11 shows the result obtained from a special test. Compaction procedures which do not take account of the problems arising from the deformability of a EPS

Fig. 11 - Swelling due to insufficient compaction.

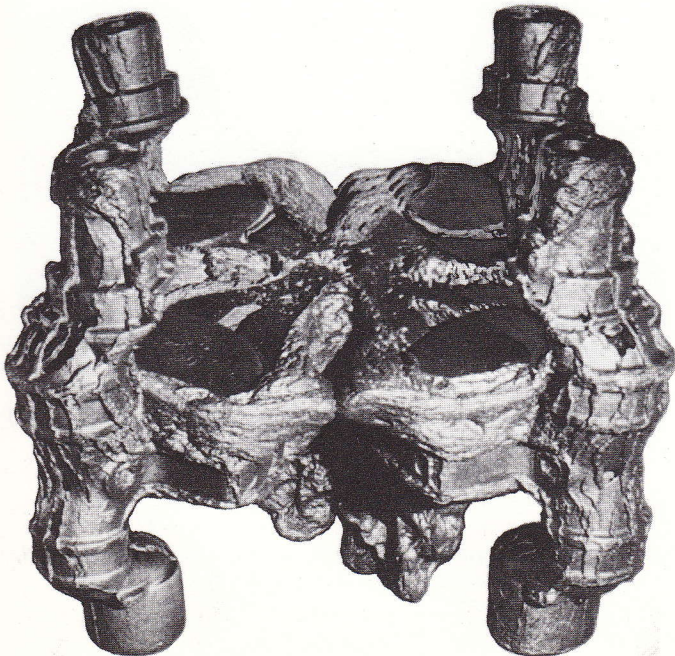

pattern may produce scrap castings with glaring alterations in the casting geometry. Fig. 12 shows an example of a crankshaft cast after defective compaction compared with crankshaft of the same type cast after adequate compaction.

On the other hand, the problems arising in compaction of the sand cannot be avoided by "easy-going" operations since, without sufficient rigidity of the mould, the static and dynamic thrust from the metal leads to swelling and collapse of the sand.

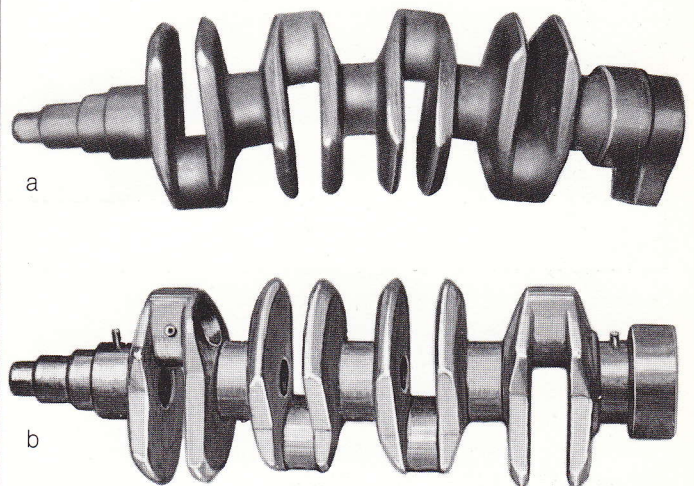
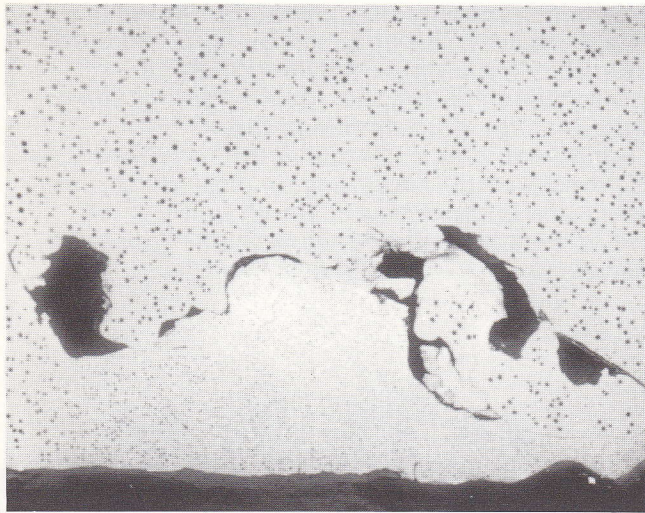

Fig. 12 - Effect of incorrect compaction procedure (a) compared with correct procedure (b).

F) Pouring

This is another stage which makes a critical contribution to the success of the casting, and must therefore be carried out according to specific procedures. In particular, it is essential to have a suitably designed system for distributing the molten metal so that the EPS can be replaced as quickly as possible, promoting as much as possible the removal of products of decomposition in a directional uniform manner compatible with the density and geometry of the pattern.

If vaporisation of the pattern occurs too slowly, or too quickly, this may cause the mould to collapse by caving-in and consequently incomplete pouring, or as a



a

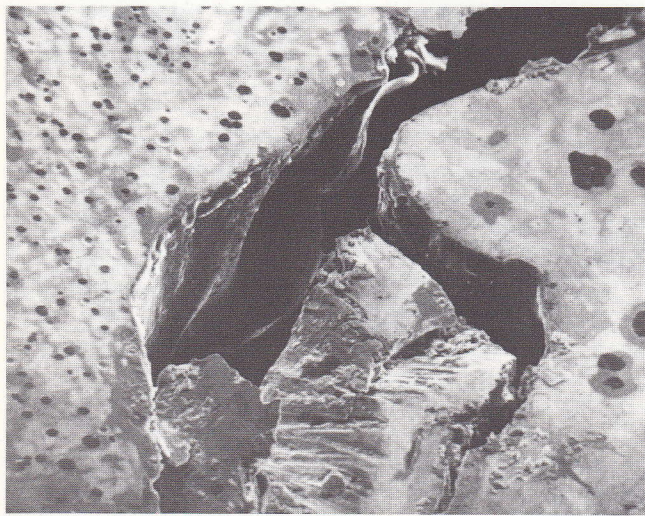

b

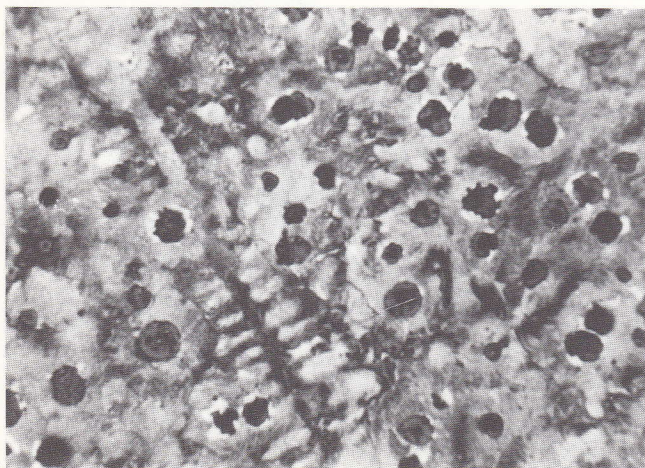

c

Fig. 13 - Cold lap: a) (20x); b) (150x); c) Localised dendrite (x150).

result of fluidisation of parts of the mould, with more or less serious alterations to the geometry of the casting. Other defects in pouring may arise due to the conditions of heat exchange between the stream of liquid metal and the decomposing EPS front. It is important to take account of the temperature drop in the advancing stream as heat is given up to the EPS, in order to avoid veining defects in the castings, or simply cold joints all the way through.

Excessive cooling of the liquid metal stream may also lead to metallurgical defects which may be found in the form of structural defects in the metal matrix (diffused or localised dendritism, the presence of carbides due to super-cooling, discontinuities of secondary origin or connected with entrapment of gas etc.). Some defects of this type are shown in Fig. 13 (a, b, c).

Other microscopic defects may be found connected with the phenomena of mould collapse, located in the running/feeding system; in such cases the metal stream may take up fragments of coat which may affect crystallisation of the graphite, particularly in the case of spheroidal iron, or sand particles which remain as discontinuities in the metal matrix, as shown in Fig. 14; these defects may have an adverse effect on the mechanical properties of the cast component.

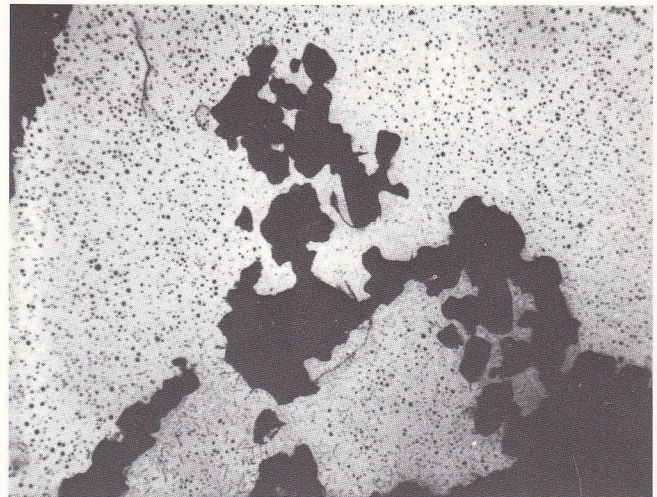

Fig. 14 - Sand inclusion (x10).

Conclusions

The stages of the "Policast" process, now at an advanced stage of development at the Teksid iron foundries, have been described, its advantages stated and its problems pointed out, with special reference to product defects. The individual items of equipment required to carry out the various stages into which it is divided have already been designed and some have, to a large extent, been constructed and tested; for the others, basic experimental checks have already been carried out to verify the validity of the principle. For this purpose, in conjunction with Fata European Group S.p.A., a plant for preliminary studies has been constructed for testing and perfecting this equipment by carrying out all stages of the process in succession, from fabrication of the patterns to pouring. This is an experimental plant where all the critical operations are fully mechanised, even though under manual control. By preparing small sample lots of finished castings it has been possible to establish that the problems described can all be solved and the solutions adopted can be extended, with good prospects for reproducibility of the quality levels achieved, to industrial-scale production.

A pilot plant is now being designed by Fata which, by producing significant batches with automatic equipment, will make it possible on the one hand to ascertain the level of reproducibility of the metallurgical, physical, mechanical and dimensional characteristics of the castings produced by the "Policast" process and, on the other, quantify with sufficiently close approximation, the economic advantages expected.

REFERENCES

- (1) Shroyer, H.F. *Cavityless casting mold and method of making same*. U.S. Patent N. 2830343, 15 Apr. 1958.
- (2) Duca, A., M.C. Flemings, and H.F. Taylor. *Transactions of the American Foundrymen's Society*, 70 (1962), 801-810.
- (3) Butler, R.D., and R.J. Pope. *Some factors involved in full mould casting with unbonded sand moulds*. *The British Foundryman*, 4 (1964), 178-191.
- (4) Kobzar, A.I. and E.G. Ivanyuk. *Russ. Cast. Prod.*, 7 (1975), 302-303. In H. Kowalke, *Zur thermischen Auflösung verlorener Polystyrolschaumstoff modelle beim Vollformgiessen von Seriengussteilen*. Thesis for doctorate at the Technische Hochschule, Darmstadt, 1980.